Operation Manual

TH9120A/D

Hipot Tester

Changzhou Tonghui Electronic Co., Ltd.

www.tonghui.com.cn

Contents

Chapter 1 Introduction.....	1
1.1 Introduction.....	1
1.2 Conditions of Use.....	2
1.2.1 Power \nearrow	2
1.2.2 Ambient Temperature and Humidity.....	2
1.2.3 Preheating.....	2
1.2.4 Precautions.....	2
1.3 Volume and Weight.....	3
1.4 Safety Requirements.....	4
1.4.1 Insulation Resistance.....	4
1.4.2 Insulation Strength.....	4
1.4.3 Leakage Current.....	4
1.5 Electromagnetic Compatibility.....	4
Chapter 2 Precautions for Usage.....	5
2.1 Operating Specifications.....	5
Chapter 3 Panel.....	11
3.1 Front Panel.....	11
3.2 Rear Panel.....	12
Chapter 4 Operation.....	14
4.1 Interface Structure Overview.....	14
4.2 SYSTEM Setup.....	15
4.2.1 System Test Parameter Settings.....	15
4.2.2 System Environment Parameters Setting.....	20
4.2.3 System Communication Setup.....	22
4.3 Meas SETUP.....	23
4.3.1 AC Withstanding Voltage Test Mode.....	24
4.3.2 DC Withstanding Voltage Test Mode.....	25
4.3.3 Insulation Resistance Test Mode.....	26
4.3.4 Pause Mode.....	28

4.3.5 OSC Detection Mode Setup	29
4.3.6 Pin Detection Mode Setup	30
4.4 TEST Setup	31
4.4.1 OFFSET	33
4.4.2 List Display and Step Display	34
4.5.1 Offset of the Test Cable / Fixture	35
4.5.2 Sampling Operation of Standard Capacitor.....	35
4.5.3 Method of Connecting the DUT	35
4.5.4 Test Procedures	36
4.6 Voltage Breakdown Test.....	39
4.6.1 Brief description	39
4.6.2 Operation instruction	39
4.7 File Storage	41
4.8 HANDLER	43
4.8.1 Brief Introduction	43
4.8.2 External Control Line Legend.....	44
4.8.2.1 Take the Internal Power Supply as an Example	44
4.8.2.2 Take the External Power Supply as an Example.....	46
4.8.2.3 Timing Diagram	47
5.1 Remote Control Interface.....	48
5.1.1 RS232C Interface Instruction.....	48
5.1.2 GPIB Interface Instruction	57
5.2 Serial Port Commands Instruction.....	60
5.2.1 SCPI Commands.....	60
5.2.2 DISPlay Subsystem Commands	60
5.2.3 FUNcTion Subsystem Commands	61
5.2.4 SYSTem Subsystem Commands.....	78
5.2.5 MMEM Subsystem Commands	85
5.2.6 USB Subsystem Commands	86
5.2.7 FETCH Subsystem Commands	87

5.2.8 Other Commands	88
Chapter 6 Specification	90
Chapter 7 Warranty.....	92

Declaration

The descriptions contained in this manual may not cover all information about this instrument. Introductions to the improvements of the instrument in performance, function, internal structure, outer appearance, accessories, packing material, etc. are subject to change without notice. If you find any inconformity of this manual with our instruments, please contact us for further consultation by the address listed on the cover.

Chapter 1 Introduction

Thank you for purchasing and using our device. Before using this device, please refer to the last chapter of “Warranty” in this manual to check and confirm, if there is any differences, please contact with us in order to protect your rights and interests.

1.1 Introduction

TH9120A/TH9120D AC/DC withstanding voltage & resistance tester is designed for conducting high voltage withstand voltage test and analysis for high-voltage optocouplers and high-voltage relays, high-voltage switches, PV modules and other components with high insulation resistance. For withstand voltage test, with output power AC:200VA (10kV, 200mA) and DC:120VA (12kV,10mA), therefore it can be used to conduct the testing of withstanding voltage for the high power motor and electronic equipment, as well to do the same test for the components. For insulation resistance test, the displayable range is 0.1MΩ~50GΩ, test voltage can be set arbitrarily from 50V to 5000V. For open and short circuit check test, judge whether the DUT is reliably connected before conducting the high voltage test and then conduct the high voltage test. For display, measurement mode, time, voltage, current, resistance value, test procedure can be displayed on the screen. In addition, there is list display mode to display multiple steps of settings and sequence test results. This tester is also equipped with RS-232C, USB, HANDLER, and optional GPIB, which enable the device to work with various automatic testing systems that require high security and reliability.

The tester provides multiple test functions, typical ones:

- **AC Withstanding Voltage Test (for TH9120A only)**
The output power AC:200VA (10kV、 20mA)
- **DC Withstanding Voltage Test (for TH9120D only)**
The output power DC:120VA (12kV、 10mA)
- **Insulation Resistance Test (for TH9120D only)**
Test range is 0.1MΩ~50GΩ, test voltage is 50V~5000V, the value can be set up arbitrarily by using 1V as step.
- **OSC Check (for TH9120A only)**
Before conducting high voltage test, please determine whether the DUT is reliably connected, in order to reduce the occurrence of poor contact.
- **Pin Check**
Apply a voltage to the high-voltage and low-voltage terminals for contact inspection. When the voltage is in contact with the DUT, the voltage will form a circuit conduction, otherwise it will be an open circuit.
- **ARC Detection Function**
To judge the DUT insulation performance is poor or not by using high frequency signal
- **Breakdown Voltage Test Function**
According to the set up, gradually conduct the test on the DUT, to find out its high voltage

tolerance for analysis and improvement.

- **List Display Function:** simultaneous display settings of multiple steps and test results of sequential execution

Various communication interfaces are available which enable the device to output the test results to external equipment (such as a computer) or automatic test system conveniently.

- **RS-232C interface:** RS-232C provides convenient serial communication with the peripheral, the peripheral can conduct the set up of various functions and parameters of the tester through this interface.
- **USB DEVICE** interface and **LAN** interface
- **HANDLER** interface: this interface enable the connection of the tester and the automatic equipment, control the tester operation and feedback the test results.
- **GPIB** interface (option): this general purpose interface provides the convenience for the tester to be connected with an automatic test system including a computer and other measuring instruments

This tester also provides convenient and practical file function, which can save the measuring parameters set up by the user. It can save 100 files, at most 50 steps per file.

1.2 Conditions of Use

1.2.1 Power ⚡

Power voltage: 100V~240VAC

Power frequency: 47Hz~63Hz

Rated power: 300W

1.2.2 Ambient Temperature and Humidity

Normal Operating Temperature: 0°C~40°C, Humidity: 20%~90%RH

Reference Operating Temperature: 20°C±8°C, Humidity: < 80%RH

Storage Ambient Temperature:-10°C~55°C, Humidity:< 90%RH

1.2.3 Preheating

Warm up time after power on: ≥ 20 minutes

1.2.4 Precautions

- 1) Please do not locate and use the tester in the poor environment where it is exposed to dust, vibration, and direct sunlight, corrosive or with flammable gas, etc.
- 2) When the tester won't be used for a long time, please have it packed in its original

carton or similar carton and store in a dry and ventilated room with suitable temperature, with no harmful impurities in the air which may corrode the tester, also should avoid direct sunlight.

- 3) Before turn on the power, make sure the voltage and fuse are identical to the ones on the manual, including shape, grade, characteristics etc. If different type of fuse is used or in short circuit, then the tester may be damaged.

Input Voltage Range	Frequency Range	Fuse (slow melting)	Rated Power
110VAC (100V~120VAC)	47-63Hz	5A	300VA
220V (200V~240VAC)		5A	300VA

- 4) This tester is carefully designed to reduce the clutter interference due to the AC power input, even though should use it under the low noise environment, if this is unavoidable, please install a power filter.
- 5) Do not use the tester in locations affected by strong magnetic or electric fields. Operation in a location subject to magnetic or electric fields may cause the tester to malfunction, resulting in electrical shock or fire.
- 6) Do not use the tester in locations near a sensitive measuring instrument or receiver. Operation in a location subject, may cause such equipment may be affected by noise generated by the tester. At a test voltage exceeding 3 kV, corona discharge may be generated to produce substantial amounts of RF broadband emissions between grips on the test lead wire. To minimize this effect, secure a sufficient distance between alligator clips. In addition, keep the alligator clips and test lead wire away from the surfaces of conductors (particularly sharp metal ends).
- 7) There is a cooling fan at the rear of the tester, with right and left cooling vent, preventing internal temperature rise affecting accuracy, please make sure the tester is well ventilated.
- 8) Please do not turn on/off the power repeatedly. After turning OFF the power switch, be sure to allow several seconds or more before turning it ON again. Do not turn on/off power switch repeatedly, if you do this, the protectors of the tester may not be able to render their protective functions properly. Do not turn OFF the power switch when the tester is delivering its test voltage, you may do this only in case of emergency.
- 9) During the normal operation, please use INTERLOCK to ensure the safety. When using this tester in a cramped working space, make a box-like structure for the DUT; when testing a complicated large-scale DUT: provide a cover or other means for the DUT to prevent electric shock, cutting off the output when the cover is opened. It is also recommended that an enclosure be provided around the operating area and that output be cut off every time the door is opened, to keep the workplace safe and secure.

1.3 Volume and Weight

Dimension: 430mm (W)*132mm (H) *500mm (D)

Weight: 21kg

1.4 Safety Requirements

This tester is class I safety instrument.

1.4.1 Insulation Resistance

Under reference working condition, insulation resistance between power terminal and the shell is not less than 50M Ω ;

Under wet and hot transport condition, insulation resistance between power terminal and the shell is not less than 2M Ω ;

1.4.2 Insulation Strength

Under the reference working condition, the withstanding rated voltage between the power supply terminal and the shell is 1.5kV, AC voltage with frequency of 50Hz for 1 minute, no breakdown and arcing.

1.4.3 Leakage Current

Leakage current is not greater than 3.5mA.

1.5 Electromagnetic Compatibility

Power Transient Sensitivity, refer to requirements of GB6833.4

Conductance Sensitivity, refer to requirements of GB6833.6

Radiative Interference, refer to requirements of GB6833.10

Chapter 2 Precautions for Usage

This chapter describes the specifications and measures to be followed when using the instrument. When using this instrument, special care must be taken to ensure safety.

△! Warning: This instrument has a test high voltage output of 10KVAC or 12KVDC. If you operate the instrument incorrectly or wrongly, it will cause accidents or even death! Therefore, for your own safety, please read the precautions in this chapter carefully and keep in mind to avoid accidents.

2.1 Operating Specifications

1) Wearing Insulation Gloves

wear insulated gloves when using the instrument to protect yourself from high voltage, but try not to touch live conductors with your hands during high voltage testing.

2) Grounding

there is a safety ground terminal on the rear panel of the tester.

Please use a suitable tool to connect this ground to the electrical ground (safety ground, earth ground). If there is no good grounding, when the

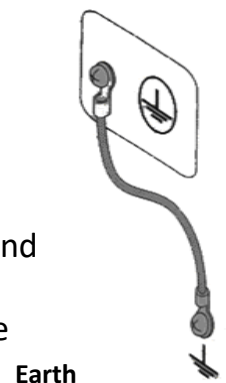

circuit of the power supply is short-circuited to the ground or the connection wire of any equipment is short-circuited to the ground, there may be high voltage in the chassis of the test instrument, which is very dangerous, as long as anyone touches the instrument chassis in the above state, an electric shock may occur. So make sure the safety ground terminal is connected to the ground

3) Test lead connection

First press the [STOP] key, make sure that the DANGER indicator is off, and then connect the test leads. When connecting the DUT with a test lead, please connect the DUT with the test lead at the RTN / LOW end first. If the test leads on the RTN / LOW end are not completely connected or dropped, it is very dangerous, because the entire DUT may be filled with high voltage. After inserting the high-voltage plug of the high-voltage test line into the HV, it must be turned 90 degrees clockwise to lock it to prevent the test line from falling off.

Before the test, you must check whether the test leads on the HV or RTN / LOW end are connected properly, no loose or detached.

4) Abort (Suspend) the test

To change the test conditions, first press the STOP switch once to make the instrument exit the test preparation state and make sure that the DANGER

light is off. If you need to take a break or leave the test place, please turn off the power switch to prevent safety hazard by accidentally touching the start switch.

5) Remote control

Special care should be taken when using the instrument in remote control mode operation, because the start and stop of the high voltage is controlled remotely, and the operator cannot know the actual working status of the instrument through the interface. **Pay special attention to the reliable remote control connection:**

- The "STOP" button, it must be connected reliably. Press the "STOP" button before replacing the DUT.
- When working in a crowded work environment, the remote control switch must have an "INTLOCK" interlock switch and a high-voltage indicator. Disconnect the "INTLOCK" interlock switch before replacing the DUT.
- When testing the voltage output, do not allow the operator or other personnel to touch the DUT, test leads, probes, output terminals and the surrounding area.

6) Test completion confirmation

If you have to touch the high-voltage area such as the DUT, test lead, probe,

or output terminal due to reconnection or other test-related conditions, please confirm:

- The power switch has been turned off or the working status displayed by the instrument is not a test status, and the DANGER light is off.
- The DUT may be filled with a high voltage on it after the test. Pay special attention to whether the DUT is completely discharged.

7) High voltage test discharge

In a high-voltage test, the test leads, test probes, and DUT are charged with high voltage. The instrument has a discharge circuit, and sometimes it still needs to be discharged after the output is cut off. There is still a danger of electric shock during discharge. Do not touch any place that may cause electric shock. At the end of the test, the discharge circuit of the instrument begins to force discharge. Do not remove the DUT during the test and before the discharge is completed.



Discharge time:

The time for which the voltage is completely discharged is determined by the test voltage used and the characteristics of the DUT itself.

During the test, the discharge of the DUT is achieved through the secondary side of the transformer (about 2K resistor). The discharge of 6000V voltage from 10uF capacitor to 30V takes about 0.1S. The instrument's fixed

discharge time of 0.2S can ensure that the discharge is complete. The internal filter capacitor of the instrument is discharged through the discharge circuit, which can ensure that the discharge is complete within 0.2S.

Assuming that high voltage is applied to the DUT is equivalent to high voltage applied to a 0.01uF capacitor in parallel with a 100MΩ resistor circuit, if the DUT is separated during the test or before the discharge is completed, the DUT is discharged to a voltage of 30V, it takes about 5S for a test voltage of 5000V and 3.5S for a 1000V.

Calculation formula of discharge time: $t = -\ln(30 / U) \times R \times C$

t: discharge time

30: Residual discharge safety voltage 30V

U: Test set voltage

R: discharge impedance of the DUT, about 2KΩ resistance

C: capacitance of the DUT

If the time constant of the DUT is known, the time required for discharging to 30V can be obtained by the above formula after the output is cut off.

8) Turn the power switch on or off

Once the power switch is cut off, if you want to turn it on again, you need to wait for a few seconds. Do not turn the power switch on and off continuously to avoid erroneous actions. It is very dangerous to continuously switch on and off especially when there is high voltage output. **When turning the**

power on or off, do not connect anything to the high-voltage output to avoid danger caused by abnormal high-voltage output.

9) In the test state, do not touch the high voltage area

When the instrument is in the test state, the high-voltage output end, high-voltage test lead, high-voltage probe, DUT, and their exposed conductors all contain dangerous high-voltage electricity. Do not approach or touch these areas.

⚠ Warning: Do not touch the alligator clips on the test line. When the instrument is in the test state, the rubber skin on the alligator clip is not enough insulation. Touching it is very dangerous!

Chapter 3 Panel

The content of this chapter is only a brief description. For specific operations and detailed explanations, please refer to the corresponding content in Chapter 4.

3.1 Front Panel

The front panel is shown in Figure 3-1.

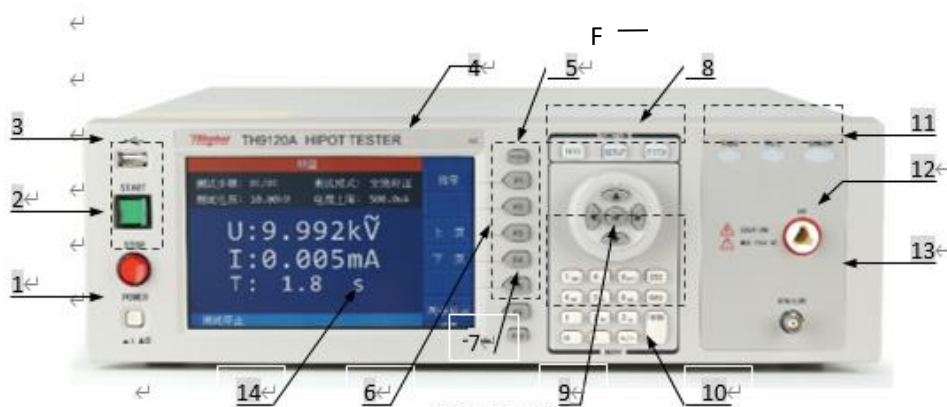

Figure 3-1

1	POWER ⚡	Turn on or off the AC power. When in the pressed position, turn on the power; when in the eject position, turn off the power.
2	START (green) STOP (red)	START: it is used to start the test. Once the test starts, the DANGER indicator lights up. STOP: the stop key is used to stop the test; it can also be used to cancel the PASS, FAIL and other prompt states.
3	USB	Used to connect external USB storage.
4	Instrument brand and model	
5	PrtScn	Screen capture key to capture the current screen picture to USB memory. The memory must be inserted in the front panel socket in advance.
6	F1~F6 Select Key	There are different functions under different display pages. There are corresponding function options on the right side of the display screen for quick selection. If the description text is blank or gray font, it means that the corresponding key is invalid.
7	FILE Key	File shortcuts to view internal and external files.

8	FUNCTION	<ul style="list-style-type: none"> ● TEST, press this key, the lamp lights, and the instrument enters the test preparation state. ● SETUP, press this key, the light will be on, and the instrument will enter the parameter setting interface. ● SYSTEM, Press this key, the light will be on, and the system setting interface will be displayed
9	Arrow keys	It is used to move the cursor on the screen. The selected parameter is displayed on a blue background.
10	Numeric keyboard	Used to enter numbers or characters (file name) if needed
11	Indicator area	<ul style="list-style-type: none"> ● PASS indicator. After the test is completed, no test data exceeding the initial setting is found, the instrument judges that the test is qualified, and the PASS light is on. ● FAIL indicator. During the test, if the test data exceeds the set value, the instrument judges that the test is unsatisfactory, and the FAIL light is on. ● DANGER indicator, this light is on as long as the test is in progress, indicating that the test is in progress. Indicates that high voltage is being output
12	HV	The high-potential terminal of the high-voltage output. This terminal is the high-voltage output terminal. When the DANGER lamp is lit and there is a high-voltage output, do not touch it.
13	RTN/LOW	High-voltage test reference terminal, that is, low-potential terminal.
14	LCD	Display test information
Table 3-1		

3.2 Rear Panel

The rear panel is shown in Figure 3-2.

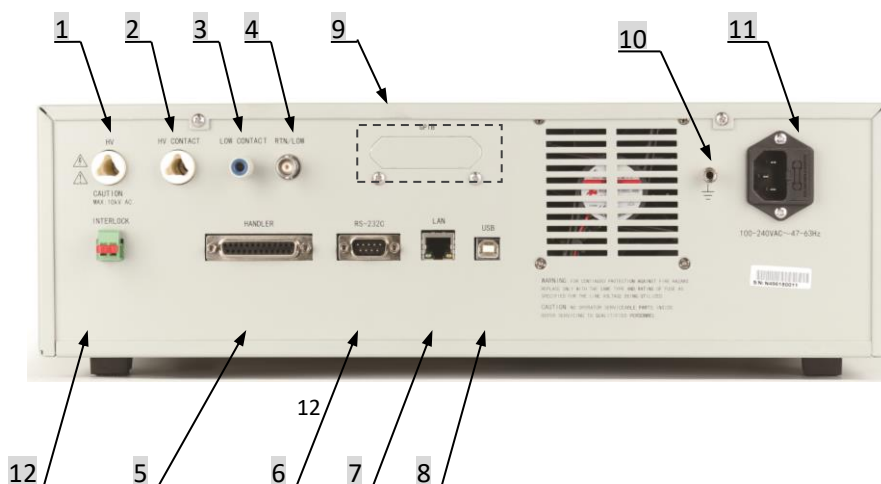

Figure 3-2

1	HV OUTPUT	High potential terminal of high voltage output. This terminal is high voltage output terminal.
2	HV CHECK	High potential check return
3	RTN CHECK	Low potential check return
4	RTN/LOW	High-voltage test reference terminal, that is, low-potential terminal.
5	HANDLER Interface	This interface can control the start / stop of the instrument and output the test results. For details, refer to the HANDLER interface description section
6	RS232C Interface	Serial communication interface to communicate with computer.
7	LAN Interface	Communication interface to communicate with computer.
8	USB Interface	Communication interface, the computer can control the instrument with the control instruction set through this interface.
9	GPIB (option)	It provides a universal parallel communication interface between the instrument and external equipment. All parameter settings and commands can be set and obtained by the computer to achieve remote control without the instrument panel.
10	Protective ground terminal	Protective ground terminal, use proper tools, to reliable ground this ground terminal.
11	Power socket	AC power socket and fuse holder, it is a three-wire power and fuse socket
12	INTER LOCK	Short-circuit both ends to allow high voltage output.
Table 3-2		

Chapter 4 Operation

4.1 Interface Structure Overview

The interface structure of the instrument is shown as follows:

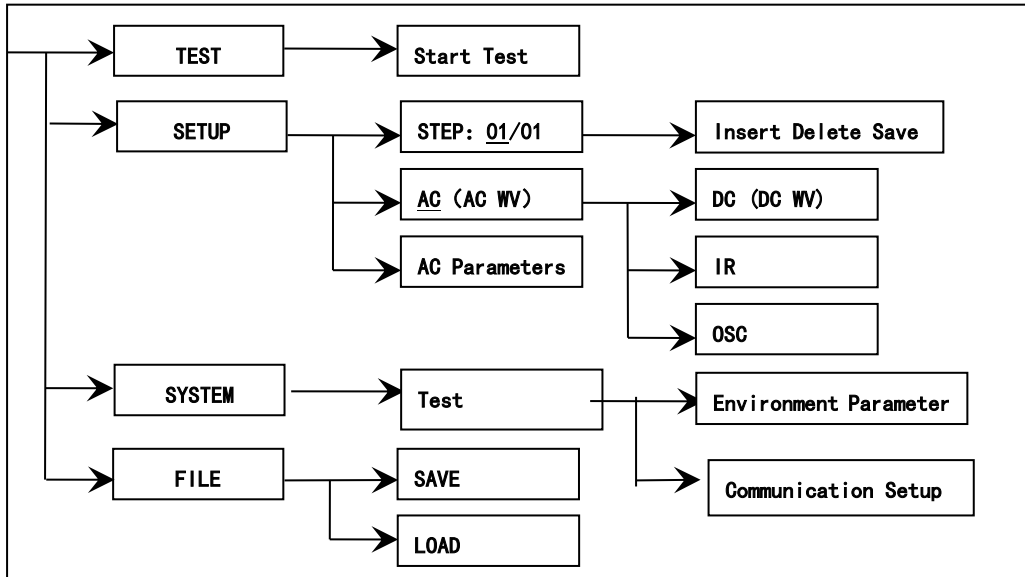

Figure 4-1 Operation Steps

Interface Instructions:

- The first line in the interface structure shows the initial states corresponding to the function keys on the panel (specific interface parameters are described in details later). The TEST interface cannot modify parameters.
- The second line in the interface shows the parameter structures of the initial interface. For example: STEP 01/01 in the SETUP interface means that it is the step 1 of the program and the total steps is 1; AC: means the AC withstanding voltage test interface; AC parameter means that other

parameters are AC withstanding voltage test parameters.

- The third line in the interface is the function toggle interface. When some function labels are selected in the second interface, the corresponding functions can be changed and their relative parameters will also vary. For instance, changing AC to OSC, the instrument will change the AC withstand voltage test mode to open / short test mode, and the 'AC parameters' of the current interface will change to 'OSC parameters' which need to be set for open / short test.

4.2 SYSTEM Setup

4.2.1 System Test Parameter Settings

Operation Instructions:

1. Press [SYSTEM] key to enter the system setting interface shown in Figure 4-2.
2. Press F1~F3 key to change the measurement, environment and interface related system settings.
3. Press [▲], [▼] key to move the cursor to the parameters you want to set. Change the parameter settings with F1~F6 keys or numeric keys.
4. If you need to input with the numeric keys, press [ENTER] to confirm, [ESC] key to reset, and [BAS] key to delete the incorrectly entered numbers or letters.

Test related parameters setting in SYSTEM are shown in Figure 4-2:

Setup items	Range	Default	Explanation
Trg. Mode	Manual External Bus	Manua I	Set the trigger mode of the instrument to start the test, only accept the trigger signal in the current trigger mode.

Trg. Dly	0.0~99.9S	0.0S	Set the delay time from the receipt of the trigger signal to the start of the measurement.
Mea. Mode	Normal Repeat Continue	Normal	Normal: Only one test is performed according to the file settings. Repeat: Perform the test multiple times as set up. Continue: Uninterrupted continuous cycle test.
Rpt. Ctn.	0~999	0	For the above repeated test mode, repeat count can be set.
Rpt. Int.	0.0~99.9S	0.0S	For repeated and continuous tests, set the time interval between two tests.
AfterFail	Continue Restart Stop	Continue	The test fails, that is, after the instrument reports FAIL, it can be set to continue the next test, or press [START] to restart, or press [STOP] first, then press [START] to start the test.
PassHold	0.2~99.9S	0.5S	Set the duration of the buzzer sound when in PASS.
StepHold	0.1~ 99.9S/key	0.2S	Set the time interval between test steps, the key means to press [START] to continue test after the test stopped.

HardAGC	ON/OFF	ON	Set the hardware automatic gain compensation function to ON or OFF.
SoftAGC	ON/OFF	ON	Set the software automatic gain compensation function to ON or OFF.
AutoRange	ON/OFF	OFF	Set the withstanding voltage automatic shift function to ON or OFF.
GFI	ON/OFF/FLO AT	ON	Set the electric shock protection function to ON or OFF.
Table 4-1			

4.2.1.1 Trigger mode

The tester can only start the test after receiving the trigger signal. This tester has four kinds of trigger modes: manual, external (EXT), BUS, automatic. The tester can only accept the trigger signal in the current trigger mode and the trigger signal is only valid under the TEST interface. Before the completion of one measurement, the tester ignores other triggers. It can only be triggered again after the measurement is finished, or press the **【STOP】** key to exit the current measurement, and then trigger the measurement again.

- Manual trigger: press the **【START】** key on the panel to start measuring.
- External trigger: input a low level greater than 10mS through the external HANDLER interface board.
- Bus Trigger: Start the test by sending a trigger signal through the RS232C or GPIB interface. The bus trigger mode can only be set by using bus commands. For details, please refer to Chapter 5.

4.2.1.2 After Fail

After Fail is test fail, which refers to the setup of handling measures after the test reports FAIL, it is divided into continue, restart and stop test.

1. When it is set to CONTINUE, when any of the STEPs determines that the DUT is defective, the test will continue until all the STEPs are completed.
2. When it is set to RESTART, when any of the STEPs determines that the DUT is defective, you can directly press the **【START】** key to restart the test.
3. When it is set to STOP, when any of the STEPs determines that the DUT is defective, you

must press the **【STOP】** key before pressing the [START] key to restart the test.

4.2.1.3 Hardware/Software Compensation

Due to the output impedance of the test signal source, the load effect that is the load change, the output voltage changes accordingly, the compensation function is used.

AC withstand voltage ACV: 50V ~ 10KV (hardware compensation is always ON, software compensation is ON by default and it can be set to OFF)

DC withstand voltage DCV: 50V ~ 499V (hardware compensation is ON by default and it can be set to OFF; software compensation is ON by default and it can be set to OFF)

DCV: 500V ~ 12KV (hardware compensation is always ON, software compensation is ON by default and it can be set to OFF)

Insulation resistance IR: 50V~499V (hardware compensation is ON by default and it can be set to OFF; software compensation is ON by default and it can be set to OFF)

IR: 500V ~ 5KV (hardware compensation is always ON, software compensation is ON by default and it can be set to OFF)

As shown in Figure 4-3: $V_o / V_s = R_L / (R_s + R_L)$

- Hardware compensation: $V_o < V_s$ due to load effect, using a hardware comparison circuit, V_o can be compensated to the same voltage as V_s in 0.1S.
- Software compensation: Due to the slow speed of software compensation, it will not cause a transient voltage shock on the DUT. Moreover, the general IR's impedance (R_L) is much larger than the output impedance (R_s) of the tester, so $V_o \approx V_s$.

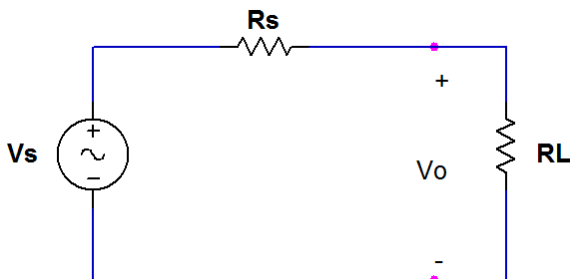
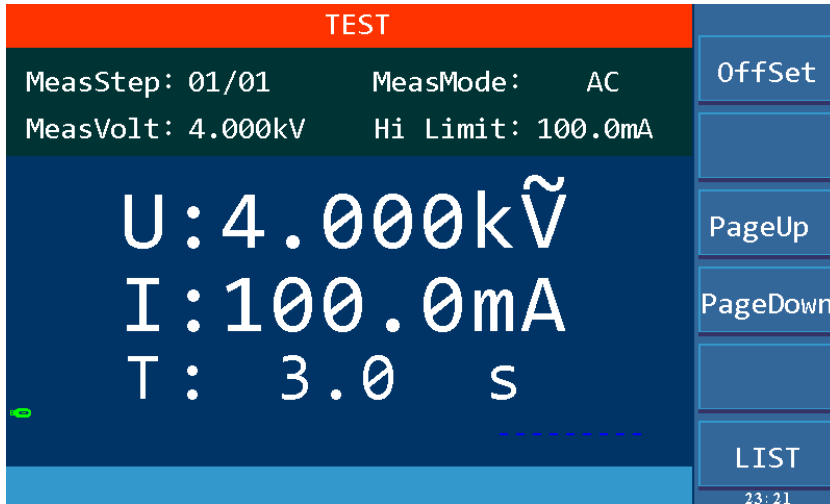

Figure 4-3

4.2.1.4 Auto Range

When the auto range, that is, the withstand voltage auto range function is set to ON, at 0.6S before the completion of the test, if the measured current can be expressed by the low current range, the current range is automatically changed to the low current range. Examples are shown in Figure 4-4.1 and Figure 4-4.2 and Figure 4-4.3.

1. If the current range in TEST is set as high current range, 10mA in Figure 4-4.1.



- But the actual current is comparatively small, 0.4mA as shown in Figure 4-4.2.

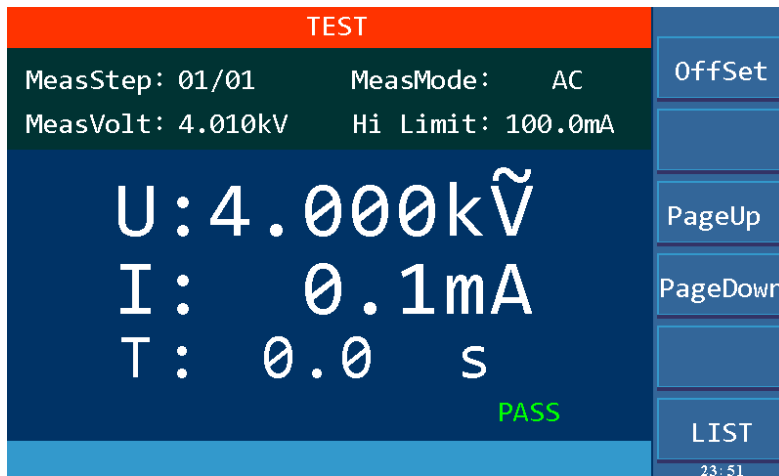

Figure4-4.2

- At 0.6S before the completion of the test, the current range is switched to the appropriate low range, which is 94.8uA in Figure 4-4.3.

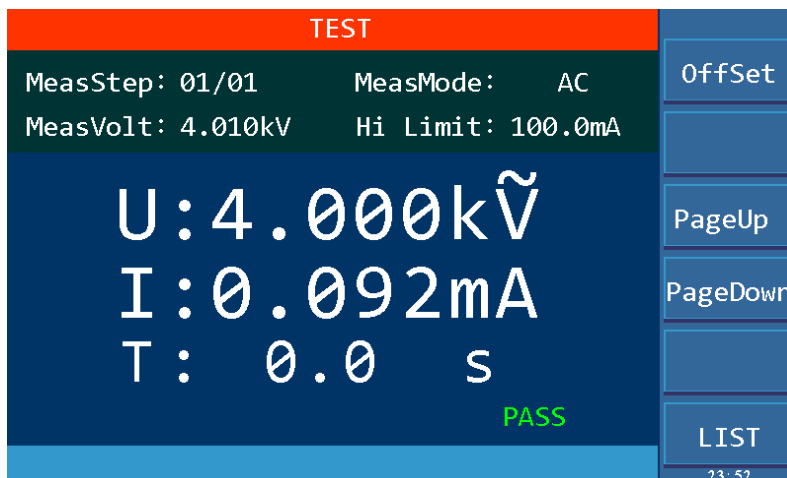

Figure4-4.3

4.2.1.5 Electric Shock Protection

Note: The output power of this tester can reach 500VA and the output current reaches 100mA (AC withstand voltage testing mode). In the event of an electric shock, the situation is already very serious, causing the operator to stun or even die. Therefore, in case that the tester allows, turn on the electric shock protection function.

The electric shock protection setting has two options, namely OFF, ON. OFF and ON means the function is turned off and on.

When the electric shock protection is set to ON, when the operator is in contact with the high voltage output terminals, as shown in Figure 4-5, the current meter measures different current values respectively, then the current flowing through the body $i_3 = i_2 - i_1$, when i_3 exceeds the limit, immediately cut off the high voltage output to protect the safety of the operator.

Figure 4-5

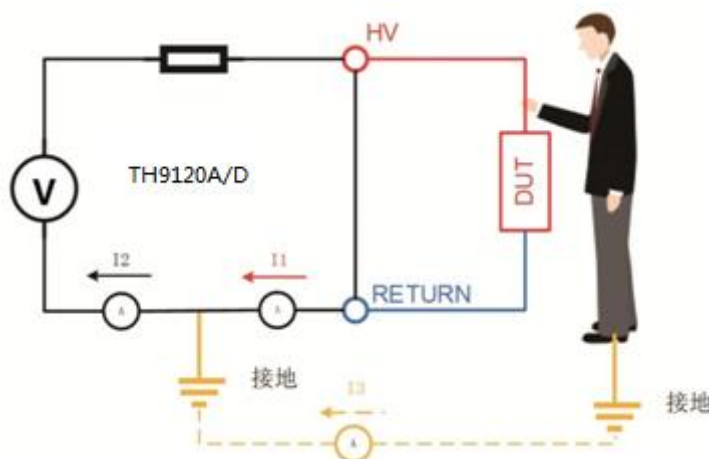

4.2.2 System Environment Parameters Setting

Operation Instructions:

1. Press **[SYSTEM]** to enter the system setting interface shown in Figure 4-2.
2. Press **[F2]** key to enter the environment-related system settings shown in Figure 4-6.
3. Press **[▲]**, **[▼]** to move the cursor to the parameter to be set. Change parameter settings via **F1~F6** keys or numeric keys.

The environment related parameter settings in the System settings are shown in Figure 4-6:

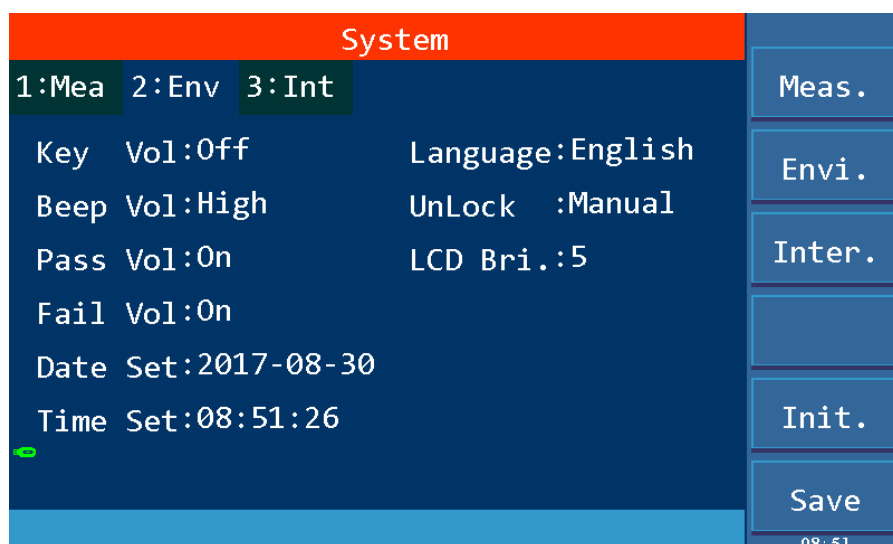

Figure 4-6 system environment parameter settings

Item	Range	Default	Explanation
Key Vol	ON/OFF	OFF	Set the key sound volume to ON or OFF.
Language	Chinese/English	Chinese	Set Chinese or English Display.
Beep Vol	Off/Low/Mid/High	High	Adjust the buzzer volume.
UnLock	Manual/Bus	Manual	Set the key lock, manual setting or bus control.
Pass Vol	OFF/ON	ON	Set the PASS beep to ON or OFF.
LCD Bri.	1~10	5	Adjust the screen brightness.
Fail Vol	OFF/ON	ON	Set the FAIL beep to ON or OFF.
Date Set	_____	_____	Set the year, month and day as needed.
Time Set	_____	_____	Set 24-hour time as needed.

Table 4-2

Key lock can be controlled by manual control and bus control. Manual control is as follows:

- a) On the non-TEST page, ie. SYSTEM or SETUP interface, press [STOP] key to enter the interface shown in Figure 4-7.
- b) Press $\llbracket F6 \rrbracket$, the key is locked; press $\llbracket F6 \rrbracket$ again to unlock. There are corresponding icons and text prompts in the lower left corner of the page.

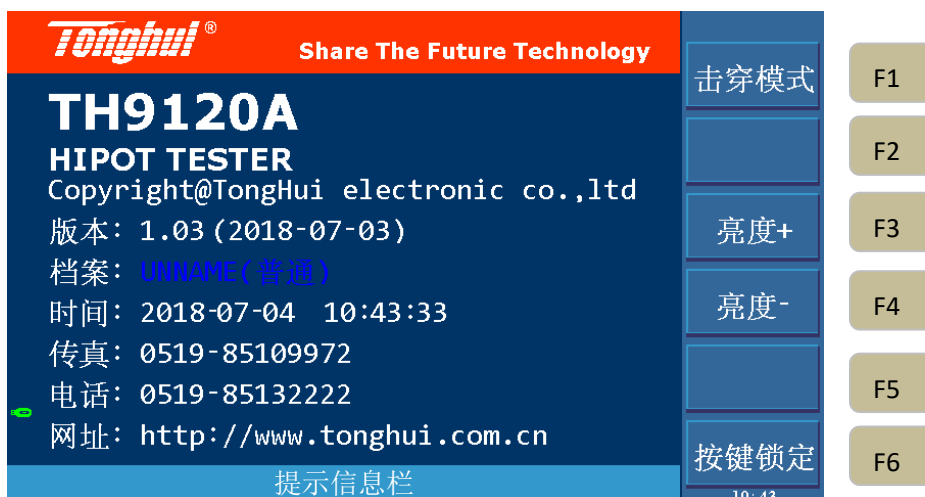

Figure 4-7 key lock and password interface

4.2.3 System Communication Setup

Operation Instructions:

1. Press `[[SYSTEM]]` to enter the system setting interface shown in Figure 4-2.
2. Press the `[[F3]]` button to enter the communication settings page.
3. Press `[[▼]]` to move the cursor to the port format setting and enter the setting page shown in Figure 4-10.
4. Select the port format to be set by using the F1~F4 keys.
5. Press `[[▲]]`, `[[▼]]` to move the cursor to the item to be set and change the parameter setting by F1~F6 or numeric key.

System communication setup as shown in Figure 4-8:

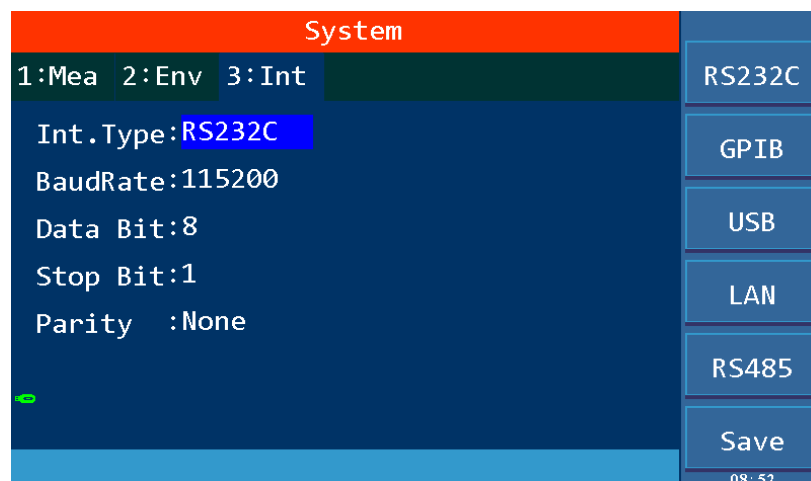

Figure 4-8 system communication setting

As can be seen from the above figure, the communication of the tester is mainly divided into RS232C, GPIB (optional), USB and LAN. For detailed explanation and detailed instructions, see Interface and Communication section in Chapter 5.

4.3 Meas SETUP

Operation Instructions:

1. Press \llbracket SETUP \rrbracket to enter the measurement setup interface shown in Figure 4-9.
2. INSERT, DELETE, NEW, SAVE or select up or down by pressing the F1~F6.
3. Press the right arrow key to move the cursor to the test mode option, as shown in Figure 4-10, uses the F1~F5 keys to select the test mode. TH9120A has test mode of AC withstand voltage, pause mode, open short circuit detection OSC and pin detection. TH9120D has test mode of DC withstand voltage, insulation resistance, pause mode and pin detection.
4. Move the cursor to the test parameter in the corresponding mode by using the arrow keys and change the parameter setting by using the F1~F6 keys or numeric keys.

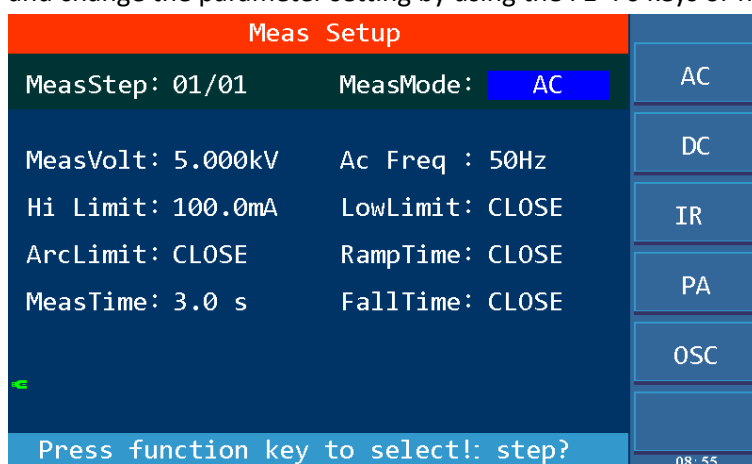

Figure 4-9 Meas Setup

Test procedures: current setting step number / total number of test steps. The change of the test steps are as shown in the table below:

Key	Function	Explanation
F1	INSERT	Add a new test item. The current item and subsequent items will move one step backward.
F2	DELETE	Delete the current test item. The subsequent item will move one step forward.
F3	NEW	Create a blank test program (PROG). Please remember to save the test program after finishing writing.
F4	SAVE	Save the current test file
F5	Up	Move to the display screen of the previous step of the current step.
F6	Down	Move to the display screen of the next step of the current step.

Table 4-3

4.3.1 AC Withstanding Voltage Test Mode

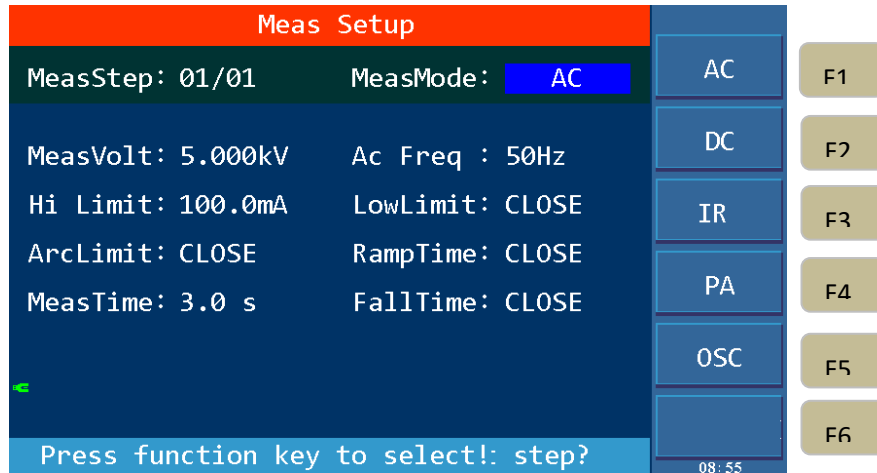

Figure 4-10 Meas Mode Setup

Setting Item	Range	Default	Explanation
MeasVolt	0.050 ~ 5.000kV, 0 — CLOSE	CLOSE	Set the voltage required for AC withstanding voltage testing.
Ac Freq	50Hz or 60Hz	50Hz	Select the frequency for AC withstanding voltage testing.
Hi Limit	0.001 ~ 120.0mA	500.0uA	Set the high limit of the test current. The voltage is ≤ 4kV, the current can reach 120mA; the voltage is >4kV, the current is up to 100mA.
Low Limit	0.001mA ~ Hi Limit, 0 — CLOSE	CLOSE	Set the low limit of the test current. The low limit must be ≤ high limit or Close.
Arc Limit	1mA ~ 20mA, 0 — CLOSE	CLOSE	Set the allowable AC arc current high limit. CLOSE means no requirement for arc.
Ramp Time	0.1 ~ 999.0s, 0 — CLOSE	CLOSE	Set the time required to rise to the set voltage. Close the ramp time, the voltage ramp is completed during the first cycle of the test.
MeasTime	0.3 ~ 999.0s, 0 — Continue	3.0S	Set the measure time for the AC withstanding voltage testing. Set to 0 means that the test is continued until the STOP key is pressed to end.

FallTime	0.1~999.0s, 0 — CLOSE	CLOSE	The time it takes to drop from the set voltage to the low voltage. CLOSE means that the test time is finished and the voltage output is cut off directly.
Table 4-3			

4.3.2 DC Withstanding Voltage Test Mode

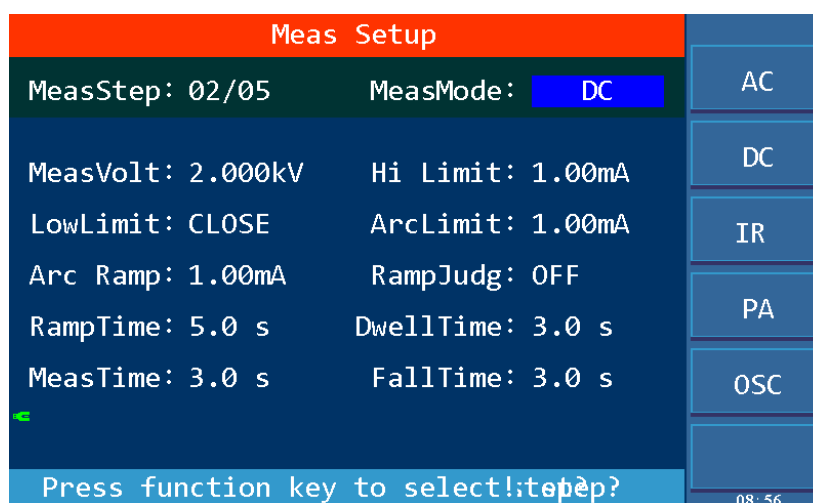

Figure 4-11 DC Withstanding Voltage Setup

Setting item	Range	Default	Explanation
MeasVolt	0.050~6.000kV, 0 — CLOSE	CLOSE	Set the voltage required for DC withstand voltage testing.
Hi Limit	0.0001mA~25mA	500.0uA	Set the high limit of the test current. The voltage is < 1.5kV, the maximum current can reach 20mA; the voltage is ≥1.5kV, the maximum current can reach 25mA.
Low Limit	0.0001mA ~ Upper Limit, 0 —CLOSE	CLOSE	Set the low limit of the test current. The low limit must be ≤ the high limit or Close.
Arc Limit	1mA~10mA, 0 —CLOSE	CLOSE	Set the allowable DC arc current high limit. Close means no requirement for arc.
Arc Ramp	1mA~10mA, 0 —CLOSE	CLOSE	Set the high limit of the arc current when the DC voltage rises. Close means no requirement for arc when voltage rises.
RampJudg	CLOSE or ON	CLOSE	When the RampJudg is set to ON, the DC withstand voltage testing judges whether the current test value exceeds the set

			value of current high limit when performing the ramp time. When the RampJudg is set to Close, the DC withstand voltage testing does not judge whether the current test value exceeds the set value of current high limit when performing the ramp time.
Ramp Time	0.1~999.0s, 0 — CLOSE	CLOSE	Set the time required to rise to the set voltage. When Ramp Time is set to Close, the voltage rise is completed during the first cycle of the test.
DwellTime	0.1~999.0s, 0 — CLOSE	CLOSE	Set the time needed for dwell (the current high limit and low limit are not judged within the dwell time, but should not exceed the high limit of the set current grade).
MeasTime	0.3~999.0s, 0 — Continue	3.0S	Set the measure time for the DC withstanding voltage testing. 0 indicates that the test is continued until STOP key is pressed.
Fall Time	0.1~999.0s, 0 —CLOSE	CLOSE	The time it takes to drop from the set voltage to low voltage. CLOSE means that the test time is over and the voltage output is cut off directly. (The DUT may be charged).
Table 4-4			

4.3.3 Insulation Resistance Test Mode

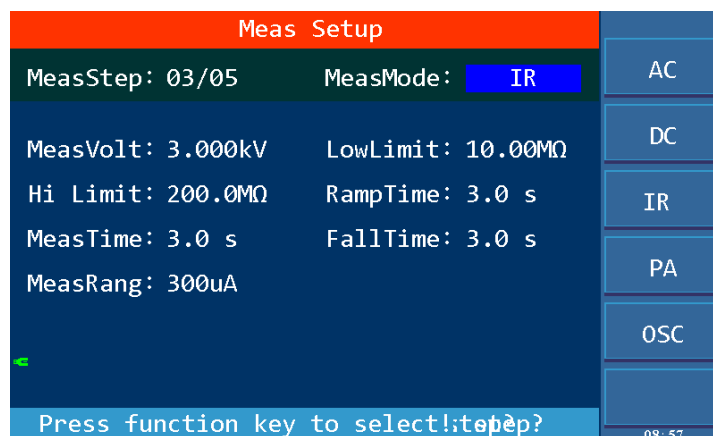

Figure 4-12 IR Test Setup

Setting item	Range	Default	Explanation
MeasVolt	0.050~5.000kV, 0 —CLOSE	CLOSE	Set the voltage required for the insulation resistance test.

Lowlimit	0.1M~50GΩ	1.000MΩ	Set the insulation resistance low limit.
Hi Limit	Low limit~50GΩ, 0 —CLOSE	CLOSE	Set the high limit of the insulation resistance, which is greater than the low limit of the insulation resistance or Close.
Ramp Time	0.1~999.0s, 0 —CLOSE	CLOSE	Set the time required to rise to the set voltage. Close the ramp time, the voltage ramp is completed during the first cycle of the test.
MeasTime	0.3~999.0s 0 — Continue	3.0S	Set the measurement time for the insulation resistance test. 0 indicates that the test is continued until STOP key is pressed.
Fall Time	0.1~999.0s, 0 —CLOSE	CLOSE	The time it takes to drop from the set voltage to the low voltage. Close means the end of the test time, directly cut off the voltage output.
MeasRang	Auto, 10mA, 3mA,300uA,30uA , 3uA,300nA	Auto	Set the current measurement range of the insulation resistance. When in Auto, it will automatically switch to the corresponding range according to the change of the test value. The fixed range is fixed to the selected range.
Table 4-5			

MeasRang: Select the appropriate current range for **IR**, calculate the current value according to the test voltage and the insulation impedance of the DUT, ie $I = U/R$, and then select the appropriate current range accordingly. Relationship between the current range and resistance measurement range is shown in table 4-6.

Current Range	Resistance Measurement Range	
	Set Voltage 50V~499V	Set Voltage 500V~5000V
10mA(3~10mA)	0.1MΩ~1MΩ	0.1MΩ~4.5MΩ
3mA(0.3~3mA)	0.5MΩ~4.5MΩ	3.0MΩ~15.0MΩ
300uA(30~300uA)	3.0MΩ~15.0MΩ	10.0MΩ~45MΩ

30uA(3~30uA)	10.0MΩ~45MΩ	35.0MΩ~450MΩ
3uA(0.3~3uA)	45MΩ~0.45GΩ	0.40GΩ~4.5GΩ
300nA(20~300nA)	0.40GΩ~4.9GΩ	4.0GΩ~50.0GΩ
Table 4-6		

4.3.4 Pause Mode

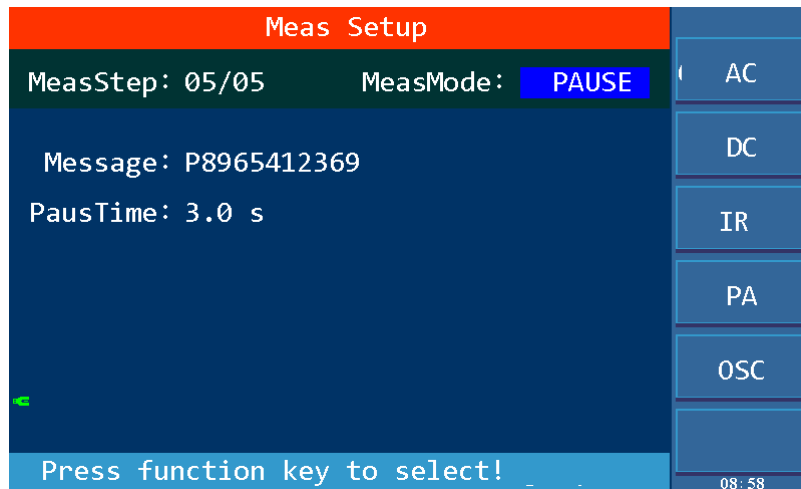

Figure 4-13 Pause Mode Setup

Message: message prompt string, you can enter English letters, Arabic numerals and [.] and [-], you can enter up to 16 characters.

PausTime: the action mode of setting the pause mode

- a) When set to continue test, the ending of the pause mode would be either the **【START】** key on the front panel is pressed, or the external **【START】** signal is retriggered.
- b) When set to 0.3~999.0s, if the set time finishes, the pause mode ends.

4.3.5 OSC Detection Mode Setup

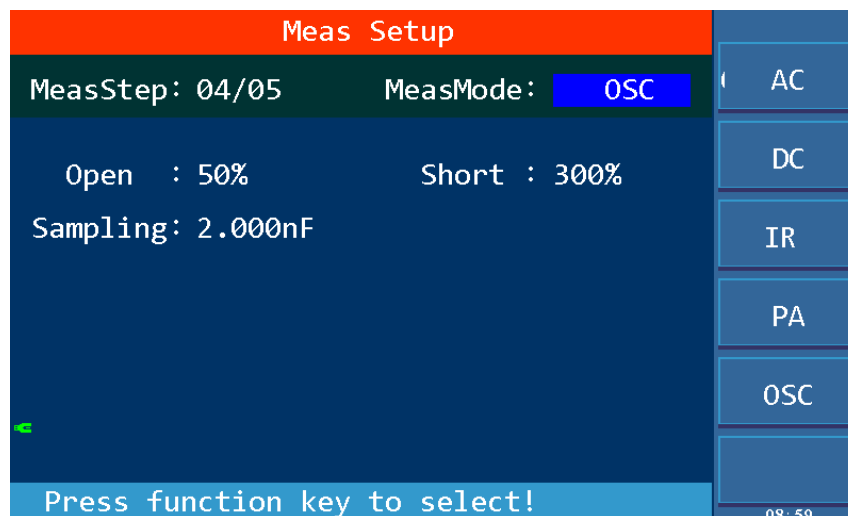

Figure 4-14 OSC Detection Setup

Set Up	Range	Default	Explanations
Open	10%~100%, Stepping 1%	50%	Set the conditions for judging the test result of open, expressed as a percentage of the test value and the sampling standard value.
Short	100%~500% 0 — CLOSE Stepping 10%	300%	Set the conditions for judging the test result of short, expressed as a percentage of the test value and the sampling standard value. 0 means Close, that is, no short circuit determination is made.
Sampling	0.001~40nF	10.0nF	Set the standard capacitor value for OSC check. You can enter a standard value by using the numeric keys, or you can obtain a value as a standard value by sampling.

Table 4-7

Sampling : Move the cursor to Sampling, as shown in Figure 4-15. Input the standard value by using numeric key, then press $\llbracket \text{ENTER} \rrbracket$ to confirm. This sampling can also be done by using $\llbracket \text{F1} \rrbracket$ key as shown in the figure. After pressing the $\llbracket \text{F1} \rrbracket$ key, the instrument enters the standard value sampling state, when sampling, the tester outputs an 600HZ frequency, 100V AC signal and the current flowing through the DUT is obtained in 1S. (There is voltage output when sampling, please pay attention to safety). The capacitance value displayed by the tester is not the actual capacitance value, but the sampled current value after impedance conversion, which should be similar to the actual installed capacitance value between the test terminals.

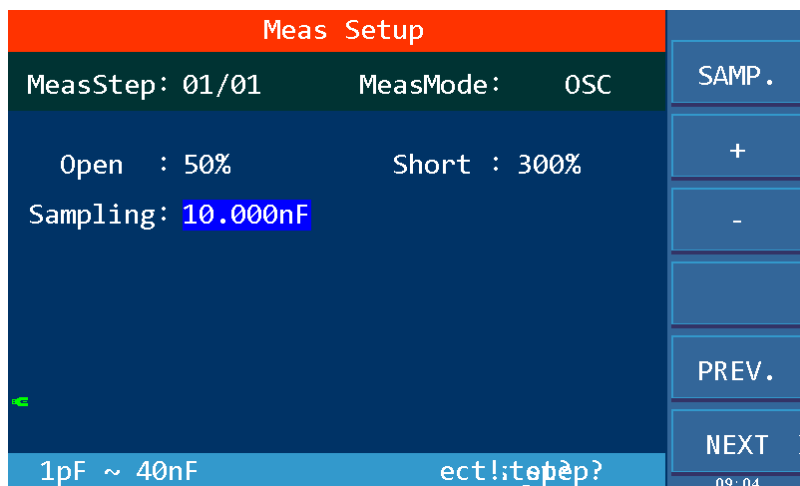

Figure4-15 Sampling Setup

4.3.6 Pin Detection Mode Setup



Figure 4-16 Pin Detection Setup

Items	Range	Default	Description
Test Voltage	0.1~0.5kV	0.100kV	Set the voltage value for pin detection
Current Low Limit	0.001~5mA	500.0uA	Set the low limit of the current used as the basis for detecting the open pin.
Table 4-8			

4.4 TEST Setup

Operation Instructions:

1. Press **[TEST]** to enter the AC Test interface as shown in Figure 4-17.1.
2. Press F1 to offset. Press F3 and F4 key to display the main parameters of different test steps as shown in Figure 4-17.2, Figure 4-17.3, Figure 4-17.4 and Figure 4-17.5. F6 is LIST interface.

In the TEST interface, the high voltage can be started to measure the high voltage of the DUT, its test parameters must be set correctly in the setting interface in detail. After measurement starts, the center of the tester screen displays three data in large font. The real-time test data are displayed during the test, after the test is completed, if the **[STOP]** key is not pressed, then the previous test result is displayed.

See Figure 4-17.1 ~ Figure 4-17.5 for details.

The upper one is the high voltage output voltage, and the withstand voltage's unit is kilovolts (kV);

The middle one is the test value, the withstand voltage testing shows current, unit is milliamps (mA), microamperes (uA), the insulation resistance shows resistance, unit is mega ohms (MΩ), GΩ (GΩ), OSC check shows capacitance, unit is nanometer (nF); Pin test shows current

The lower one is time, including ramp time, dwell time (DC withstand voltage testing only), measurement time, fall time, and interval time between steps. There is a corresponding time prompt in the information prompt bar, indicating time type that this time belongs to. If the user sets the test time to 0, that is to continue test, the test time shown is the time after entering the test state, and this count will count from zero when the count is greater than 65535. If "FAIL" is not reported, the test status must be exited by pressing "STOP". Unit is seconds (S).

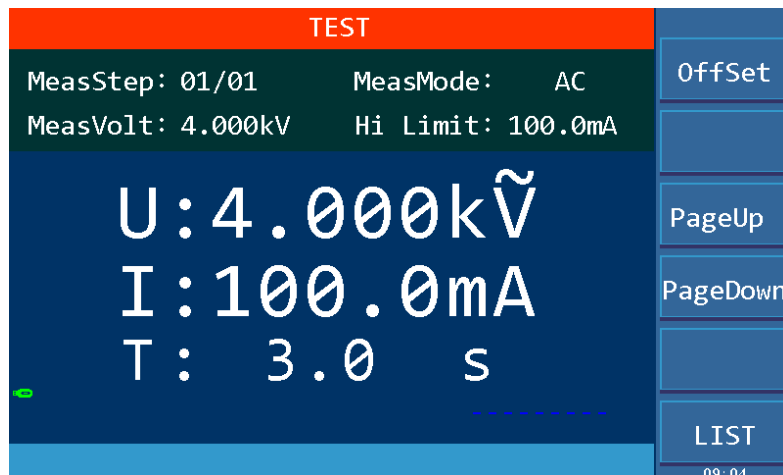

Figure 4-17.1 AC Test Interface

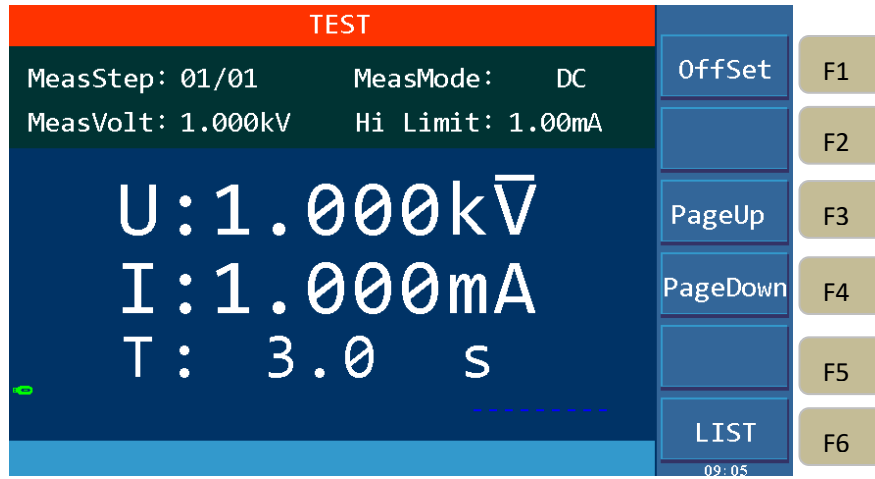

Figure 4-17.2 DC Test Interface

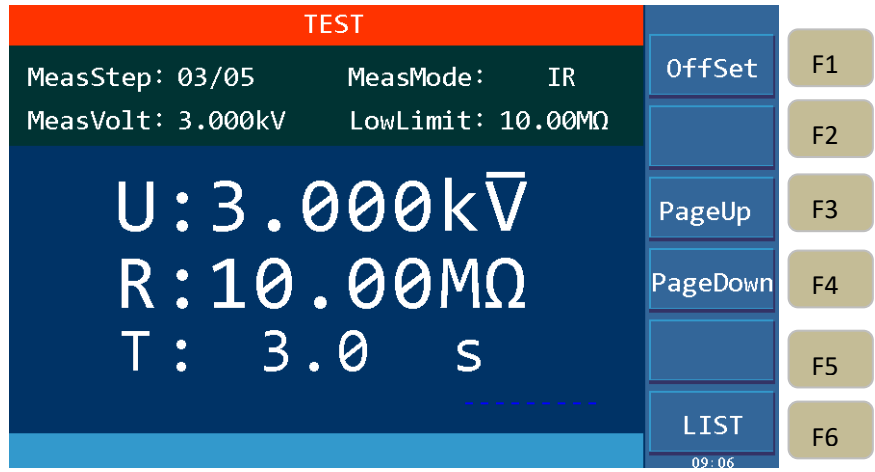

Figure 4-17. 3 IR Test Interface

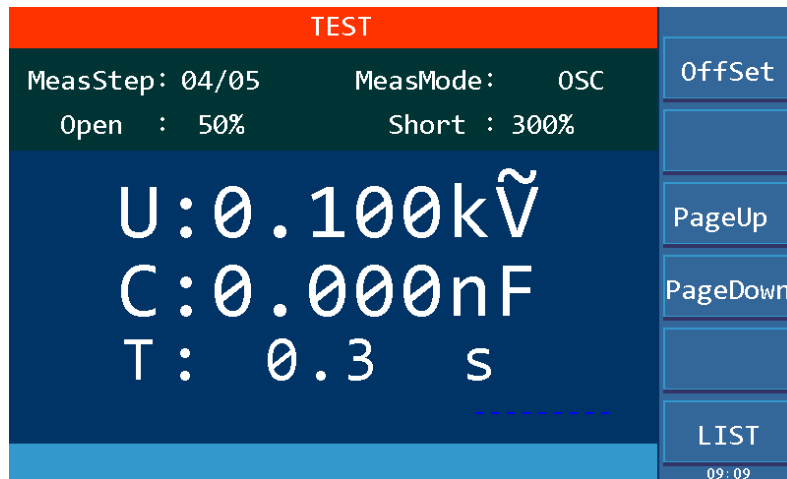

Figure 4-17.4 OSC Test Interface

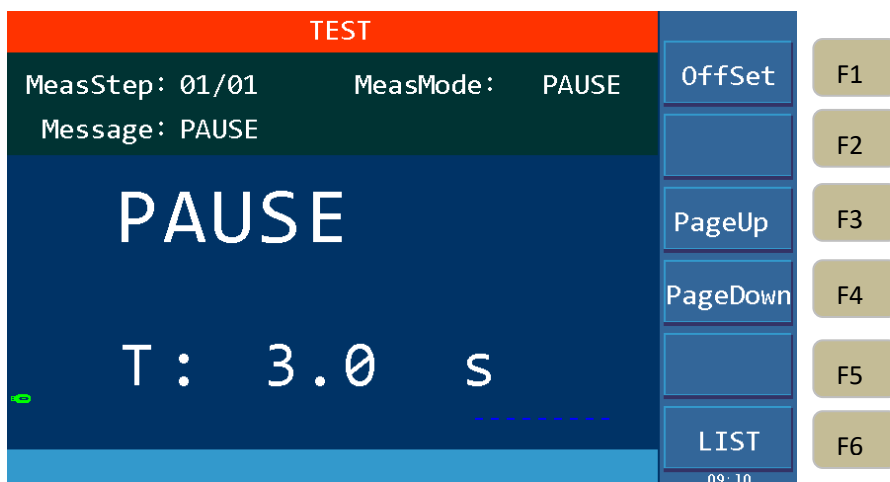

Figure 4-17.5 PAUSE Mode Interface



Figure 4-17.6 Pin Detection Mode Interface

4.4.1 OFFSET

Before testing, due to the change of working environment and position of the test cable, there may be some base numbers when the tester is in no-load test. For some customers who pursuing accurate measurement can conduct offset in TEST interface. The specific steps are as follows:

1. Remove the DUT from the test cable or fixture first and then set up the test conditions in the SETUP interface.
2. Press \llbracket TEST \rrbracket key to enter TEST interface, press F1 to offset. The tester starts to measure the leakage current of the test cable and display the current, use the present test value as the zero value.
3. After pressing F1 offset key, the DANGER indicator flashes and the voltage output time is 5S. (When the set test time is larger than 5S, if the time is less than 5S, the output voltage time is according to the set test time.)

4.4.2 List Display and Step Display

In addition to the original step display interface, this tester also adds a list display interface, which can display multi-step parameters. In the tester TEST interface, press the F6 key to switch the interfaces.

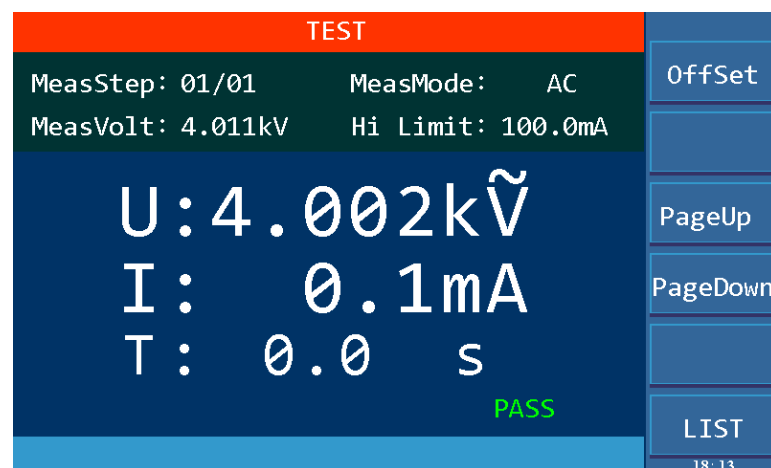

Figure 4-18 STEP Display Interface

On the STEP display page, in addition to test steps, test mode information, there is also large font shows the set voltage and current high limit before starting the test. After pressing **【START】** to start the test, the first line of the large font shows the test value of output voltage, the second line shows the actual measured value of the current, and the third line is time. Test result is shown in the lower right corner. As shown in Figure 4-18.

The screenshot shows the 'LIST' interface with the following table:

TEST				
STEP	MODE	VOLT	LIMIT	
01	AC	1.500kV	1.00mA	
02	DC	2.000kV	1.00mA	
03	IR	3.000kV	10.00MΩ	
04	OSC	0.100kV	2.000nF	
05	PAUSE	P8965412369		

Navigation buttons on the right include: OffSet, PageUp, PageDown, and STEP. The bottom status bar shows '18:15'.

Figure 4-19 LIST Display Interface

On the LIST display page, the first column is the test STEP, the second column is the test MODE, the third column is the VOLT (test set value), the fourth column is the set LIMIT, and the fifth column is the test results. After pressing **【START】** to start the test, the third column shows the present voltage test value, and the fourth column shows the actual measured current value or resistance value. As shown in Figure 4-19.

4.5.1 Offset of the Test Cable / Fixture

1. First remove the DUT from the test cable or fixture and confirm the set test conditions.
2. Press [TEST] to enter the test interface, press F1 offset key, the tester starts to measure the leakage current of the test cable and display the current and the test value is used as the zero value.
3. After pressing F1 offset key, the DANGER indicator flashes, the voltage output time is 5S (when the test time is set to be greater than 5S), if the test time is less than 5S, the output voltage is set according to the set test time.
4. DANGER light stops flashing after the end of offset.

4.5.2 Sampling Operation of Standard Capacitor

1. Before Open Short-Circuit check mode (OSC) testing or testing a new capacitor DUT or replacing a capacitor DUT, the standard capacitance value must be sampled first, or input a capacitor value as the standard value.
2. Offset on the TEST interface first before sampling the standard capacitor value. Each time the test cable or fixture is replaced, the offset must be performed to ensure the accuracy of the test.
3. When sampling the standard capacitance value, first use the standard sample of the capacitor to be tested as the DUT, and measure the capacitance value according to the sampling in OSC mode as the standard value for testing.
4. When performing the open short circuit check mode (OSC) test, the condition to judge the OPEN/SHORT is according to the sampled capacitance value.

4.5.3 Method of Connecting the DUT

1. First make sure that the tester has no voltage output and the DANGER indicator not lit nor flashing.
2. Then connect the test cable for low potential to the RTN/LOW or HV2 terminal of the tester, short circuit this test cable to the high voltage test cable and insert the high voltage test cable into the high voltage output terminal HV1 to make sure that there is no high voltage output.
3. Finally, connect the test cable of low potential (RTN/LOW or HV2) to the DUT first and then connect the test cable of high potential HV1 to the DUT.

4.5.4 Test Procedures

4.5.4.1 AC/DC/IR Test Procedures

1. Connect the DUT correctly according to the connection method of the DUT. Press **【TEST】** key to enter the measurement interface, at this time, the pending test steps that have been set up are displayed, the small font shows the test step, test mode and test voltage, withstanding voltage test shows current upper limit value, insulation resistance shows resistance lower limit value. The middle large font shows the set voltage, current and time.
2. Press the **【STOP】** key to prepare for the test. Press the **【START】** key to start the test, when this key is pressed, there will be a high voltage output, and the DANGER light flashes. **Warning: At this time, it is in the test state and there is a large voltage output.** The first line in large font shows the actual measured high voltage output value, the second line is the measured current value or resistance value, the third line is the corresponding time, there is message prompt in the lower left corner.
3. Pass Judge
When all the test modes are completed and the test result in the lower right corner displays PASS, it is judged as pass and cut off the high voltage output, the rear panel also gives a pass signal, the buzzer simultaneously acts.
4. Fail Judge
If the test value is detected abnormal, it is judged as fail and immediately cuts off the output. The rear panel gives a fail signal and the buzzer operates simultaneous, and it will continue until the **【STOP】** key is pressed. The test result in the lower right corner displays FAIL.

Explanation Table for Fail:

Displayed Test Result	Meaning
High Limit	Test value is greater than the set high limit.
Low Limit	Test value is smaller than the set low limit.
RC FAIL	Current arc exceeds high limit.
FI FAIL	Ground failure interrupt
HORT FAIL	The instrument output current is greater than the internal set current limit. This limit cannot be changed, the AC test has a short-circuit current of 200 mA and a DC test of 40 mA.
Table 4-9	

In any case, if you want to abort the test output, just press the **【STOP】** key.

4.5.4.2 OSC Test Procedures

1. Connect the DUT correctly according to the connecting method of the DUT.
Press the **【TEST】** key to enter the Test interface, at this time, the pending test steps that have been set up are displayed, the small font shows the test steps, the test mode, and the open circuit judge percentage and the short circuit judge percentage. The large font in the middle shows the set voltage, capacitance value and time.
2. Press the **【STOP】** key to prepare for the test.
Press the **【START】** key to start the test, when this key is pressed, there will be a high voltage output, and the DANGER light will flash. The first line of the large font shows the actual measured high voltage output value, and the second line is the measured capacitance value, the third line is the corresponding time, there is a message prompt in the lower left corner.
3. Pass Judge
When all the test modes are done and the test result in the lower right corner displays PASS, it is judged as pass, and cut off the high voltage output, the rear panel also gives a pass signal, the buzzer simultaneously acts.
4. Failure Judge
If the test value is detected abnormal, it is judged as fail and immediately cuts off the output. The rear panel gives a failure signal and the buzzer operates simultaneous, and this will continue until the **【STOP】** key is pressed. The test result in the lower right corner displays FAIL.

Explanation Table for Fail

Displayed Test Result	Meaning
OPEN	Open capacitor, the percentage of capacitance test value and sampling standard value is smaller than the set percentage of open circuit judge.
SHORT	Short capacitor, the percentage of capacitance test value and sampling standard value is greater than the set percentage of short circuit judge.
Table4-10	

In any case, if you want to abort the test output, just press the **【STOP】** key.
The capacitance value displayed by the tester is not the actual capacitance value, but the value of the sampled current after impedance conversion, which should be approximate to the actual capacitance value installed between the test terminals.
Take a 3-coil inductor as an example: the capacitance between 1-2 is about 300P, 1-3 is about

200P, 2-3 may be short-circuited. First confirm the open circuit value, do not connect the DUT, sampling: $C_s=100P$; Then confirm the standard value, and connect the DUT multiple times to record the sampling Data range: $C_s=350P\sim 450P$; Finally confirm the short circuit value, short circuit 2-3, multiple sampling data range: $C_s = 550P \sim 650P$.

Parameter setting calculation:

- 1) Assume $C_s=400P$
- 2) OPEN value: the low limit is $100P/400P=25\%$, the high limit is $350P/400P=88\%$, and it is recommended to take 60%;
- 3) SHORT value: the low limit is $450P/400P=112\%$, the high limit is $550P/400P=138\%$, and it is recommended to take 125%.

4.5.4.3 Pin Detection Test Procedures

1. Connect the DUT correctly according to the connecting method of the DUT.

Press the **[TEST]** key to enter the Test interface, at this time, the pending test steps that have been set up are displayed, the small font shows the test steps, the test mode, and test mode and low limit of current. The large font in the middle shows the set voltage, current value and time.

2. Press the **[STOP]** key to prepare for the test.

Press the **[START]** key to start the test, when this key is pressed, there will be a high voltage output, and the **DANGER** light will flash. The first line of the large font shows the actual measured high voltage output value, and the second line is the measured current value, the third line is the corresponding time, there is a message prompt in the lower left corner.

3. Pass Judge

When all the test modes are done and the test result in the lower right corner displays PASS, it is judged as pass, and cut off the high voltage output, the rear panel also gives a pass signal, the buzzer simultaneously acts.

4. Failure Judge

If the test value is detected abnormal, it is judged as fail and immediately cuts off the output. The rear panel gives a failure signal and the buzzer operates simultaneous, and this will continue until the **[STOP]** key is pressed. The test result in the lower right corner displays FAIL.

Explanation Table for Fail

Displayed Test Result	Meaning
Low end poor	Test for low-end poor contact
High end poor	Test for high-end poor contact
Table4-11	

4.6 Voltage Breakdown Test

4.6.1 Brief description

The voltage breakdown test is a destructive test of the ultimate ability of the DUT in the real test.

4.6.2 Operation instruction

5. 1. On the non-TEST page, ie. SYSTEM or SETUP interface, press **【STOP】** to enter the interface shown in Figure 4-20
6. 2. Press the F1 key , select the test mode of BDV(Break Down Voltage), press the **【TEST】** key to enter the test interface, as shown in Figure 4-21.
7. 3. Press F3 or F4 to select the NormStep and VoltStep, use the direction keys and the scroll wheel to move the cursor to the test parameter item to be set. The corresponding operations can be performed through the F1~F6 keys and the numeric keypad.
8. 4. Start the test after setting is completed. As shown in Figure 4-22

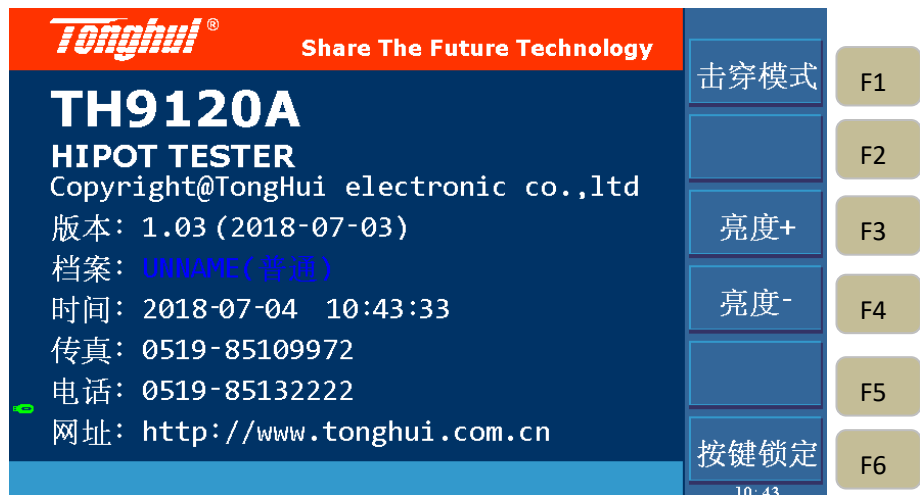

Figure 4-20

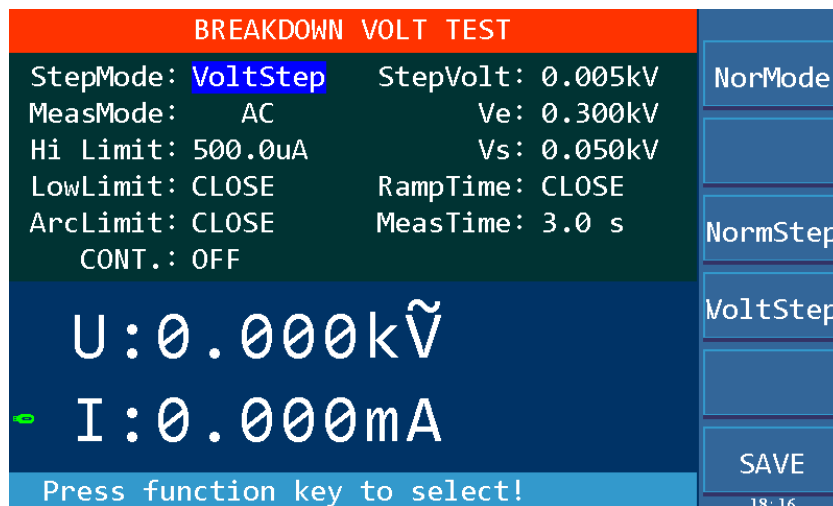

Figure 4-21

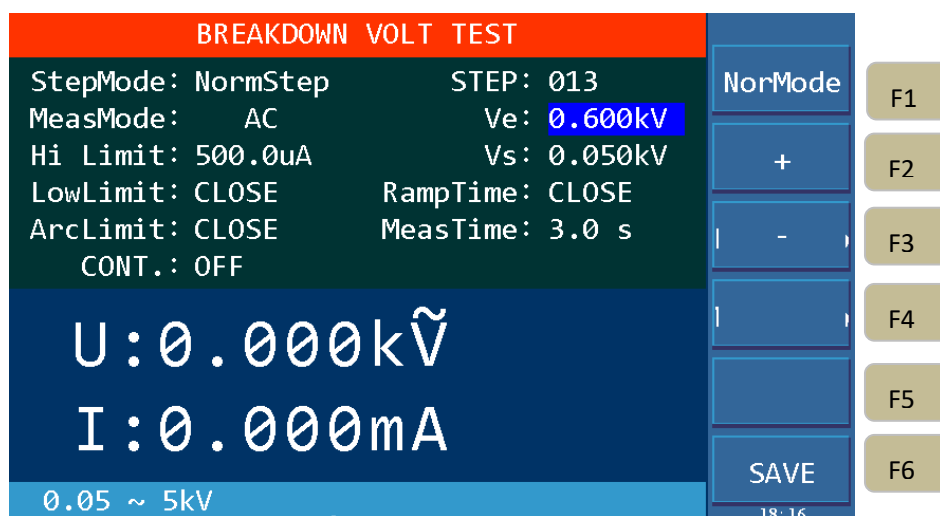

Figure 4-22

Parameters Function Explanation:

Item	Range	Default	Explanation
Step Mode	Norm Step/Volt Step	Norm	Select to step according to the test step or test voltage.
Step	2~999	2	Only for the NormStep mode, set the voltage rise steps.
Step Volt	0.005~0.5kV	0.005kV	Only for the Volt Step mode, set the rising voltage value.
Meas. Mode	AC/DC	AC/DC	TH9120A is AC mode, TH9120D is DC mode
Ve	0.05~10kV	0.05kV	Set voltage ending value.
Vs	0.05kV~Ve	0.05kV	Set voltage starting value.
Ramp Time	0~999,0—close	Close	Set the rise time of each step.
Meas. Time	0.3~999s	3.0S	Set the test time of each step.
Hi Limit	AC: 0~20mA DC: 0~10mA	0.500mA 0.500mA	Set the high limit of leakage current.

Lo Limit	C: 0~High Limit Value	close	Set the low limit of leakage current.
	C: 0~High Limit Value	close	
	0—CLOSE		
Arc Limit	AC: 0~20mA	close	Set the high limit of Arc.
	DC: 0~10mA	close	
	0—Close		
CONT	On/ OFF	Off	Set whether to continue the test when all the setup steps are completed.
Table 4-12			

4.7 File Storage

Operation Instructions:

1. Press **[[FILE]]** key to enter the file management interface, as shown in Figure 4-24.
2. Through the F1 key, F2 key to switch between internal files and external files.
3. Move the cursor to the file to be set by **[[▲]]** , **[[▼]]** , and perform the corresponding operation through F1~F6.

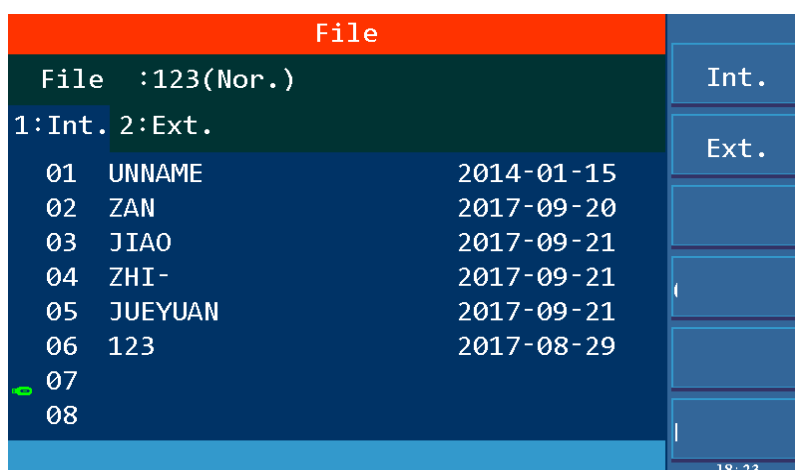

Figure4-23 Internal File Interface

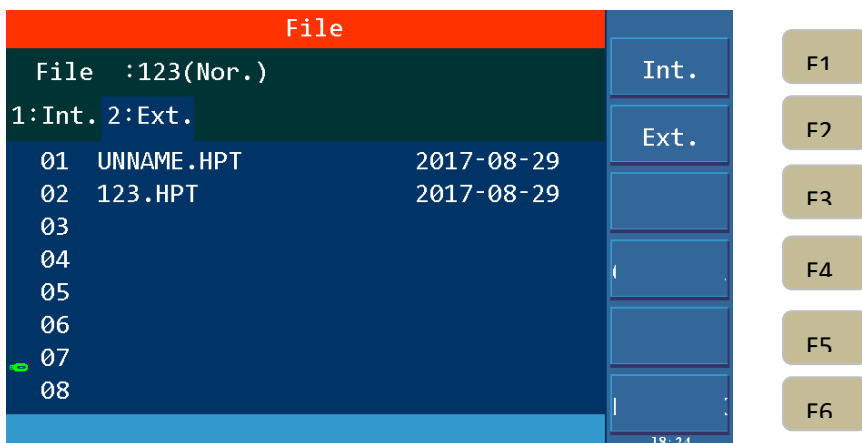

Figure4-24 External File Interface

Key	Function	Explanation
F1	New	Create a new file.
F2	Save	Save the currently loaded file.
F3	Load	Load the file as the current file.
F4	Copy All	Copy all files for batch processing.
F5	Copy	Copy internal files to U disk, copy U disk files to internal.
F6	Delete	Delete the current file.

Table 4-13

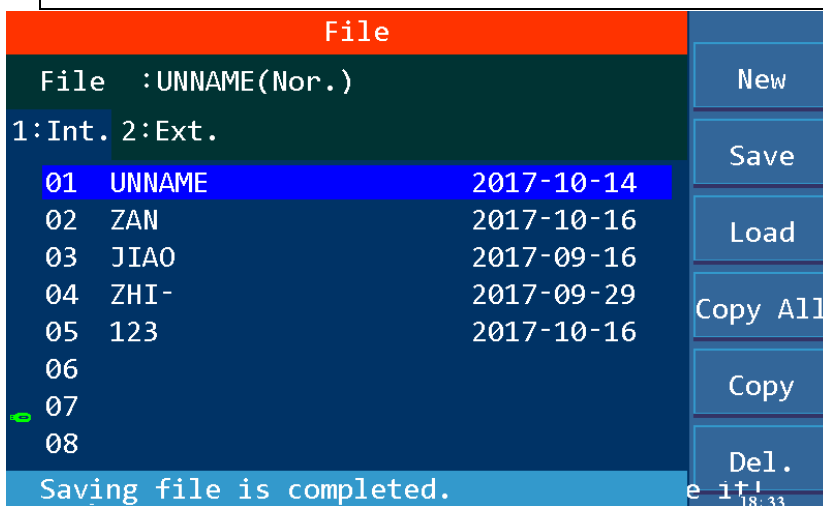

Figure 4-25 File Operation Interface

4.8 HANDLER

4.8.1 Brief Introduction

The tester provides a versatile HANDLER interface, which is primarily used for the output of test results. When the tester is used in an automated test system, the interface provides a contact signal to the system and a test result output signal. Signals can be divided into two broad categories: internal output signals and external input signals. The internal output can be divided into test result output and contact signal output. Internal signal output specifications: DC 24V, 20~40mA; External signal output specifications: DC 3V~26V (HIGH), 10mA±4mA.

Interface Pin Description:

Pin#	Signal Name	Input/Output	Description
2	/OPEN	Output	OSC OPEN output, used together with /PASS and /FAIL
3	/SHORT		OSC SHORT output, used together with /PASS and /FAIL
4	/FAIL		The output is LOW when the test result is FAIL, at this time /HIGH, /LOW, /ARC_FAIL, /GFI_FAIL and /SHORT_FAIL signal will have output (LOW action).
5	/PASS		The output is LOW when the test result is PASS, at this time /HIGH, /LOW, /ARC_FAIL, /GFI_FAIL and /SHORT_FAIL signal will not have output (all are HIGH).
6	/HIGH		Test result is HIGH FAIL, the output is LOW.
7	/LOW		Test result is LOW FAIL, the output is LOW.
19	/SHORT_FAIL		Test result is SHORT_FAIL, the output is LOW.
20	/ARC_FAIL		Test result is ARC_FAIL, the output is LOW.
21	/GFI_FAIL		Test result is GFI_FAIL, the output is LOW.
15,18	NC		Output
1	/PA	Output	When the test is started, this signal is LOW, after each PA mode, the relationship between the /PA signal and the COM terminal is changed to HIGH or LOW once.
14	/SYSTEM ERROR	Output	Internal system error signal output pin, when the output is LOW, it indicates that the system generates an internal error.
16	/EOT	Output	When this signal is HIGH, it means the test is in process; when this signal is LOW, it means the test is finished or in standby.
17	/EOS	Output	When this signal is HIGH, the test step (STEP) is currently is in process; When this signal

			is LOW, it means that the current test step (STEP) has ended without entering the next step or all test steps have ended.
12,13	+24V	Output	Internal DC voltage output
24,25	GND	-----	Low voltage side of internal voltage output
22,23	COM	-----	Low voltage side of the input/output signal
10,11	EXT_DCV	Input	+VEXT: External DC voltage input, input voltage range is +3V~ +26V.
8	/EXT_STOP	Input	External STOP signal input, act when signal status is LOW
9	/EXT_START	Input	External START signal input, act when signal status is LOW
Table4-14			

4.8.2 External Control Line Legend

4.8.2.1 Take the Internal Power Supply as an Example

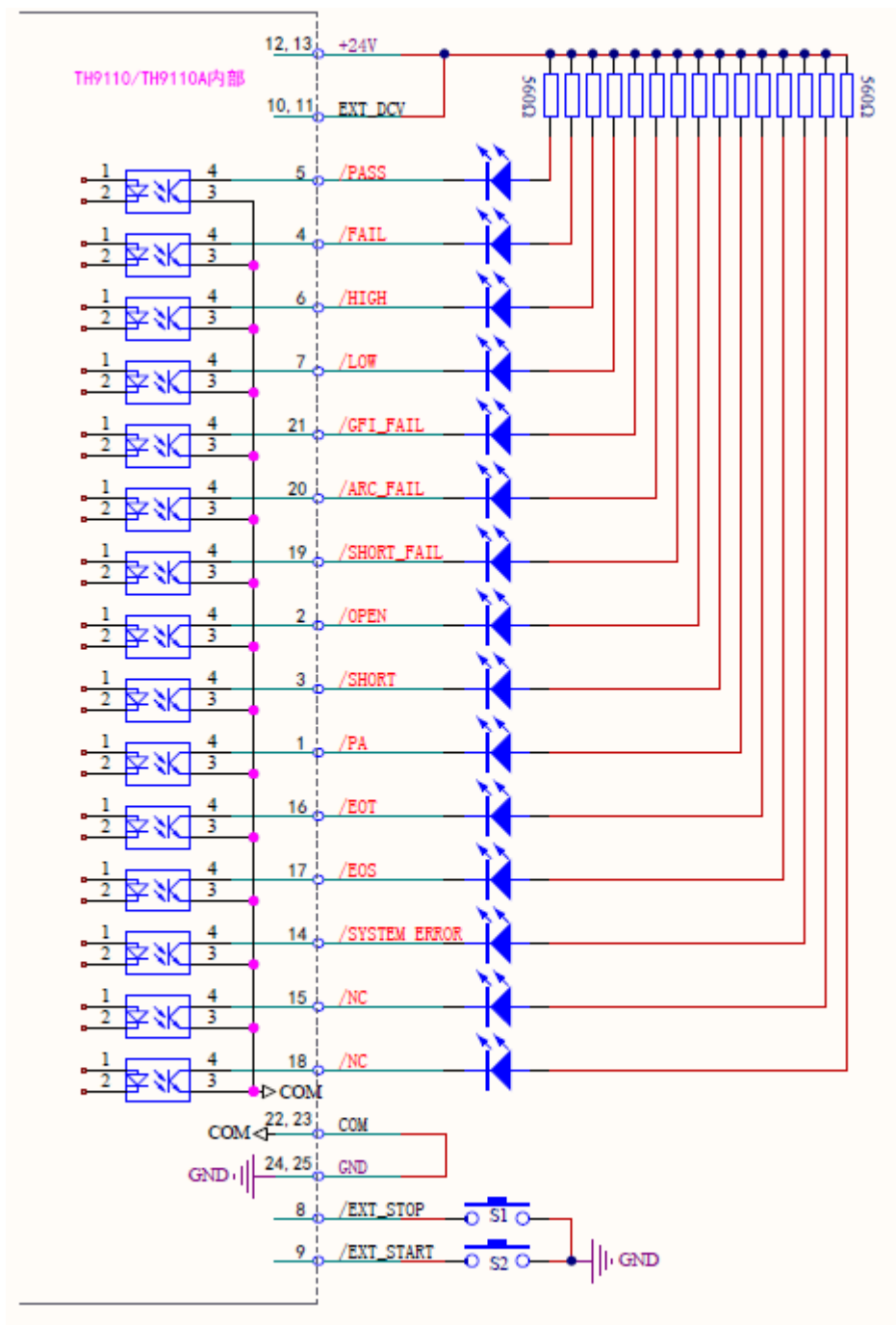

4.8.2.2 Take the External Power Supply as an Example

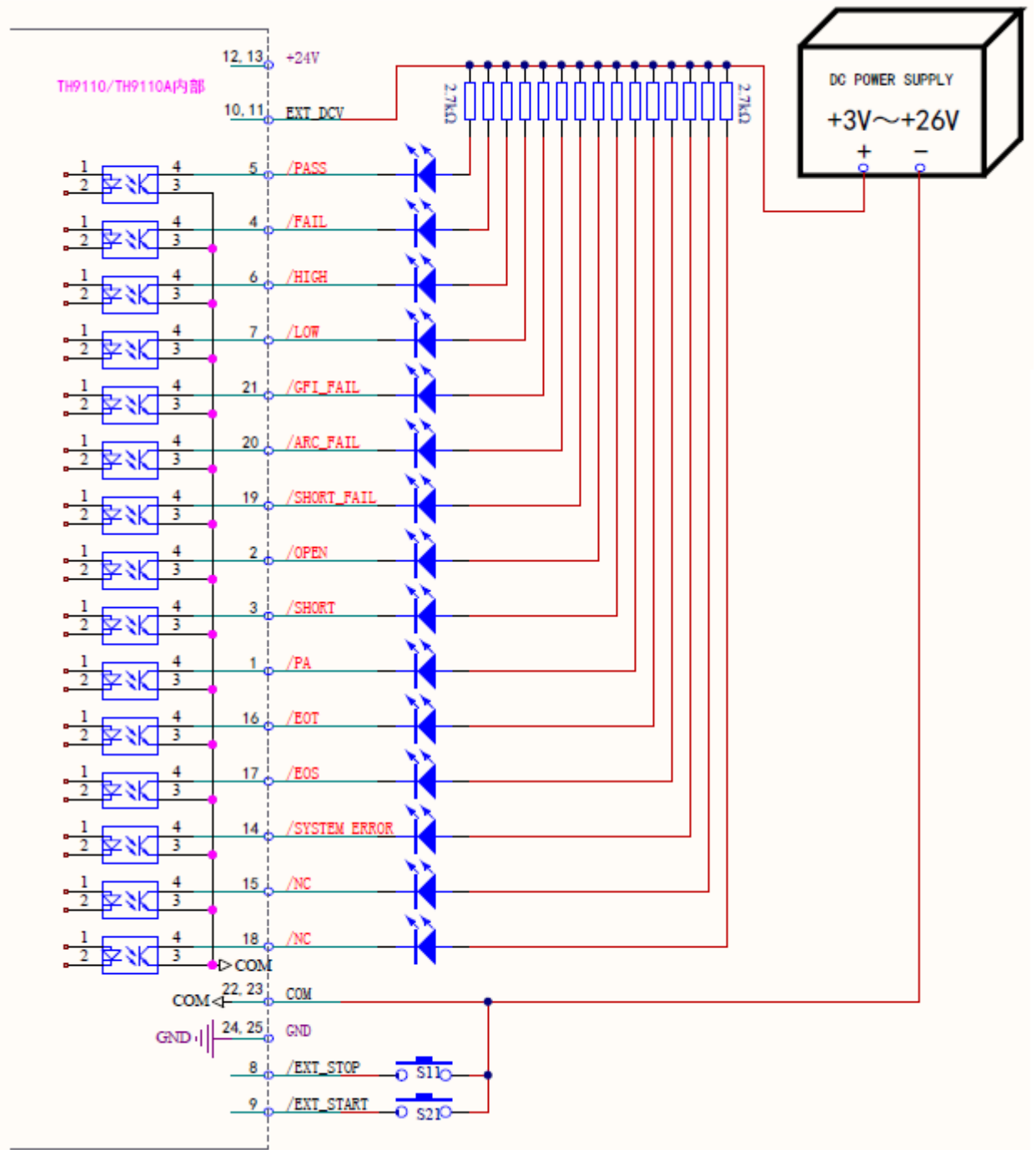

4.8.2.3 Timing Diagram

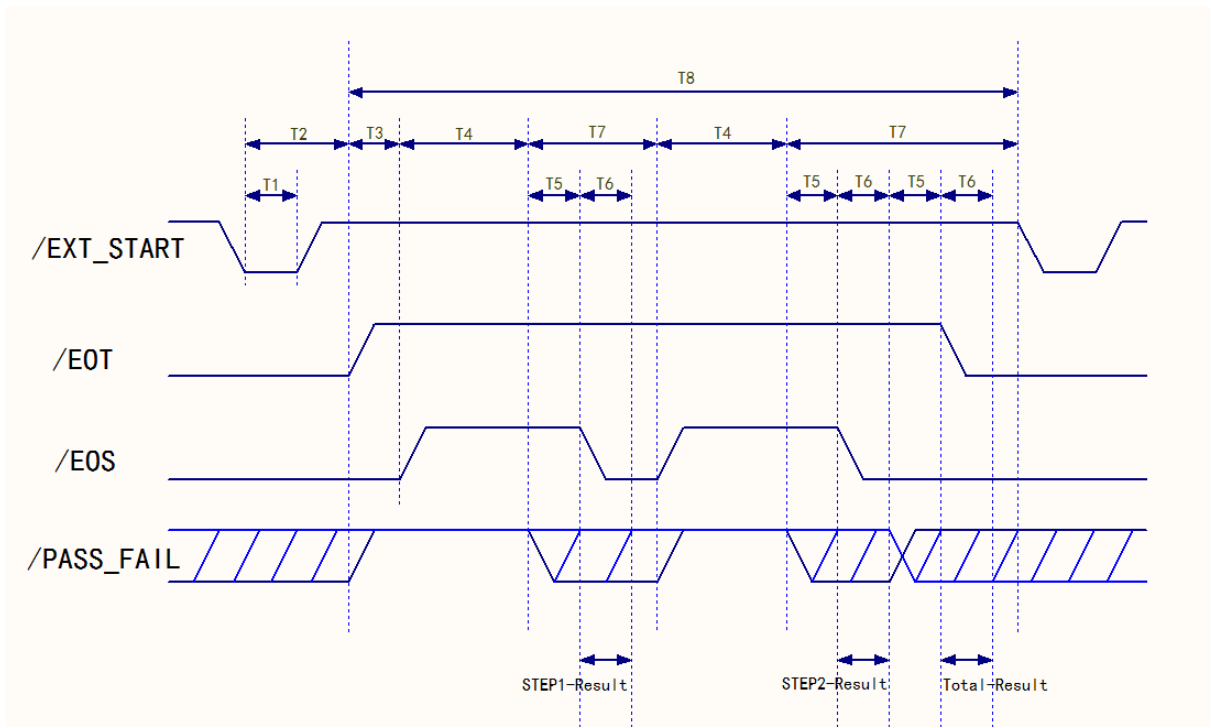

Timing Diagram—Take 2 test steps as an example

Time	Range	Explanations
T1	>10mS	Internal trigger signal(/EXT_STRAT) continue time, need about >10mS
T2	<20mS	External trigger signal(/EXT_STRAT) time needed from start to /EOT signal is cleared, <20mS
T3	-----	Time setup for the trigger delay
T4	-----	Time needed for each test steps (STEP)
T5	>10mS	/PASS_FAIL signals, stable waiting time, >10mS
T6	>10mS	/EOS continue time, result output time or /EOT signal stable waiting time, >10mS
T7	-----	Time need for each test steps completion
T8	-----	Time needed for the test files (FILE)

Chapter 5 Interface and Communication

The instrument can use RS232C serial interface (standard) or GPIB parallel interface (optional) for data communication and remote control without instrument panel, but they can not be used at the same time. They have the same programming commands but use different hardware configurations and telecommunication protocols. This chapter describes how to use the interface, for details on the use of interface commands, see Chapter 5.2.

5.1 Remote Control Interface

5.1.1 RS232C Interface Instruction

The RS232C interface provided by the tester can be used to communicate with a computer. The tester provides rich program-controlled commands. Through the RS232C interface, the computer can perform almost all functions on the tester panel.

5.1.1.1 Brief introduction of RS232C Interface

At moment the widely used serial communication standard is the RS-232 standard, which can also be called the asynchronous serial communication standard, which is used to realize data communication between a computer and a computer, and between a computer and a peripheral device. RS is the English abbreviation of "Recommended Standard", 232 is the standard number. This standard is officially published by the Electronic Industries Association (EIA) in 1969, it stipulates that one bit is transmitted by one data line at a time.

Most serial port configurations are usually not strictly based on the RS-232 standard: Use a 25-core connector on each port (IMB AT uses a 9-core connector). The most commonly used RS-232 signals are shown in the table below:

Signal	Symbol	25-core connector pin #	9-core connector pin#
Request to Send	RTS	4	7
Clear to Send	CTS	5	8
Data Set Ready	DSR	6	6
Data Carrier Detect	DCD	8	1
Data Terminal Ready	DTR	20	4
Transmit Data	TXD	2	3
Receive Data	RXD	3	2
Grounding	GND	7	5

Like most serial ports in the world, the serial interface of this tester is not strictly based on the RS-232 standard, but only provides a minimal subset. As shown in the following table:

Signal	Symbol	Connector Pin#
--------	--------	----------------

Transmit Data	TXD	3
Receive Data	RXD	2
Grounding	GND	5

This is the most easy and cost effective way to use serial ports communication.

①Note: The serial port pin definition of this tester is basically the same as the pin definition of the standard 9-core RS232C connector.

The RS232C connector of this tester uses a 9-core pin type DB socket, and the pin sequence is as shown below:

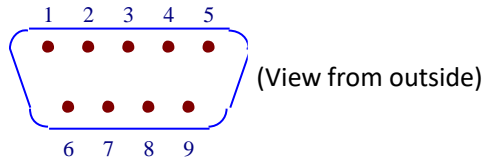

Direct connection to the standard DB 9-core hole type plug.

⚠Warning: To avoid electrical shock, turn off the power before plugging or unplugging the connector;

⚠Warning: Do not short-circuit the output terminals or short-circuit the chassis to avoid damage to the device.

5.1.1.2 Communicating with a Computer

- The tester is connected to the computer as shown:

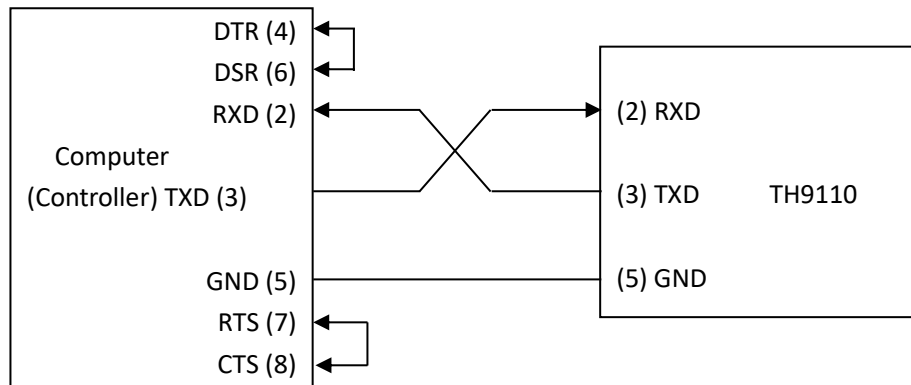

As can be seen from the above figure, the pin definition of this tester is the same as that of the 9-core connector serial interface pin used by the IMB AT compatible machine. Users can use the double-core shielded cable to make three-wire connection cable according to the diagram (the length should be less than 1.5m) or purchase the serial interface cable between the computer and the instrument from our company or directly purchase the standard DB9 core cable (cross line).

When making the connection cable, be careful to short pin 4 and 6, pin 7 and 8 on the computer connector.

- When communicating with the computer through the serial port, you should first set up the bus mode of the tester. The operation sequence is as follows:

Press the **SYSTEM** menu button → (F3 soft key) → direction key to move the cursor to the port format → **RS232C** soft key.

- Serial port main parameters

Transfer Method	Full-duplex asynchronous communication with start and stop bits
Baud Rate	9600 bps/19200bps/38400bps/115200bps
Data Bit	8 BIT or 7BIT
Stop Bit	1 BIT or 2BIT
Parity Check	No Parity/Odd Parity/Even Parity
Terminator	NL (line break, ASCII code 10)
Contact Method	Software contact
Connector	DB9 Core

- Software Protocol

Since the hardware communication is not used on the RS232 interface, in order to reduce the possibility of data loss or data error in the communication, the tester uses the character echo method for software communication. Please refer to the followings when programming computer communication software:

- 1) The command string syntax and format are described in Chapter 5.2 “Serial Port Commands Instruction”
- 2) The command sent by the host is transmitted in ASCII code, the NL (ie, newline character, ASCII code 10) is used as the terminator, the tester starts executing the command string after receiving the terminator.
- 3) The instrument will send the character back to the host immediately after receiving one character. The host should continue to send the next character after receiving the return character. If you do not receive the returned characters, there may be factors:
 1. Serial port connection failure.
 2. Check that the RS232 port function is enabled.
 3. The tester is executing a bus command and is temporarily unable to respond to serial acceptance. At this point, the last sent character is ignored by the tester, if you want to ensure the integrity of the command string, the host should resend the unreturned characters.
- 4) The tester sends information to the host only in the following two cases:
 1. The command character of the host is received normally and the character is loopback.
 2. Execute the query command to send the query result to the host.
- 5) Once the tester executes the query command, the query result will be sent immediately, regardless of whether the current command string has been completely executed. Therefore, there can be multiple queries in a command string, but the host must have a corresponding number of read results. This protocol recommends that only one query be included in a single command string.
- 6) The result of the query is sent in ASCII code string, with NL (ie. newline, ASCII code 10) as the terminator.
- 7) When the tester sends the query result, it is sent continuously (interval is about 1ms), and the host should be in the state of accepting data, otherwise, data loss may occur.
- 8) Once the host generates the query, please ensure that all query results are read (once NL

- is received, meaning end) to avoid the conflict between the query and the loopback; similarly, the host should also read all loopback characters before reading the query result.
- 9) For some bus commands that take a long time to complete, such as offset, the host should actively wait for, or respond to the user's keyboard input confirmation to synchronize the execution of the previous command, to avoid the next command being ignored or errored during command execution.
- 10) Communication software programmed with DOS application software should run under the pure DOS environment supporting serial port. If it is running under WINDOWS, it may cause errors due to different management methods of serial port.

- Serial Interface Program Example

The below example is a communication program written in C language and running in a pure DOS environment, the main function can be used by the user to expand the communication function arbitrarily, while other sub-functions illustrate how to use the serial port for input and output of the string.

```

#define PORT 0

#include "dos.h"

#include "stdio.h"

#include "stdlib.h"

#include "ctype.h"

#include "conio.h"

void port_init( int port,unsigned char code );

int check_stat( int port );          /* read serial port state(16bit) */

void send_port( int port,char c );  /* send a character to serial port */

char read_port( int port );        /* recive a character form serial
port */

void string_wr( char *ps );         /* write a string to serial port */

void string_rd( char *ps );        /* read a string from serial port */

char input[256];                   /* quary recieve bufer */

main()

```

```
{ port_init( PORT,0xe3 );/* initialize serial port:baud = 9600,no verify,1 bit
stop,8 bit data */
```

```
string_wr( "trig:sour bus;*trg" );
```

```
string_rd( input );
```

```
printf( "\n%s",input );
```

```
string_wr( "freq 10khz" );
```

```
string_wr( "func:imp:type rx;;func:smon on" );
```

```
string_wr( "voltage:level 500mv" );
```

```
}
```

```
/* write string to serial port */
```

```
void string_wr( char *ps )
```

```
{ char c;
```

```
int m,n;
```

```
while( check_stat(PORT) & 256 ) read_port( PORT );/* read data until
null */
```

```
for( ;*ps; )
```

```
{ c = 0;
```

```
for( m = 100;m;m-- )
```

```
{ send_port( PORT,*ps);
```

```
for( n = 1000;n;n-- )
```

```
{ delay( 2 ); /* wait about 2ms, use dos.h libray funtion */

    if( kbhit() && ( getch() == 27 ) ) /* if escape key keypress */

        { printf( "\nE20:Write Canceled!" );

            exit(1);

        }

    if( check_stat(PORT) & 256 )

        { c = read_port( PORT );

            break;

        }

    }

    if( n ) break;

}

if( c == *ps ) ps++;

else

    { printf( "\nE10:Write Echo Error!" );

        exit(1);

    }

}

send_port( PORT, '\n' ); /* send command end symbol */

delay( 2 );

while( !(check_stat(PORT) & 256) );

read_port( PORT );
```

```
}

/* read string from serial port */

void string_rd( char *ps )

{ unsigned char c,i;

  for( i = 0;i < 255;i++ ) /* max read 256 characters */

  {while( ! (check_stat(PORT) & 256) ) /* wait serial receive ready */

    if( kbhit() && (getch() == 27) ) /* if escape key keypress */

    { printf( "\nE21:Read Canceled!" );

      exit(1);

    }

  }

  c = read_port( PORT );

  if( c == '\n' ) break;

  *ps = c;

  ps++;

}

*ps = 0;

}

/* send a character to serial port */

void send_port( int port,char c )
```

```
{  
  
    union REGS r;  
  
    r.x.dx = port;          /* serial port */  
  
    r.h.ah = 1;           /* int14 function1:send character */  
  
    r.h.al = c;           /* character to be sent */  
  
    int86( 0x14,&r,&r );  
  
    if( r.h.ah & 128 )    /* check ah.7,if set by int86( 0x14,&r,&r ),mean  
trans error */  
  
        { printf( "\nE00:Serial port send error!" );  
  
        exit(1);  
  
        }  
  
    }  
  
/* read a character from serial port */  
  
char read_port( int port )  
  
{ union REGS r;  
  
    r.x.dx = port;          /* serial port */  
  
    r.h.ah = 2;           /* int14 function2:read character */  
  
    int86( 0x14,&r,&r );  
  
    if( r.h.ah & 128 )    /* if ah.7 be set,mean trans error */  
  
        { printf( "\nE01:Serial port read error!" );  
  
        exit(1);  
  
        }  
  
    }
```

```
        return r.h.al;
    }

    /* check the status of serial port */

    int check_stat( int port )

    { union REGS r;

        r.x.dx = port;          /* serial port */

        r.h.ah = 3;            /* int14 function3:read status */

        int86( 0x14,&r,&r );

        return r.x.ax;         /* ax.7 show serial operation, ax.8 show
serial recive ready */

    }

    /* initialize the serial port */

    void port_init( int port,unsigned char code )

    { union REGS r;

        r.x.dx = port;          /* serial port */

        r.h.ah = 0;            /* int14 function0:initial serial port */

        r.h.al = code;         /* initialization code */

        int86( 0x14,&r,&r );

    }
```

5.1.2 GPIB Interface Instruction

5.1.2.1 GPIB BUS

The IEEE488 (GPIB) universal parallel bus interface is an internationally accepted intelligent instrument bus interface standard. IEEE is the English abbreviation of Institute of Electrical and Electronics Engineers, 488 is the standard number. Through this interface, it can communicate with a computer or other intelligent device, and can easily form an automatic test system together with other test instruments. Multiple test instruments can be connected simultaneously on the same bus. For this tester, it adopts the IEEE488.2 standard, and the interface board is an option. The control command system is open, and the user can use the computer operation interface provided by the tester, or can program the system according to the control command to achieve the purpose. The control command system supports most of the functions of the tester, that is to say, almost all functions of the tester can be operated on a controlled computer to realize the remote control of the tester.

When using tester's GPIB system, the following points should be noted:

- The total cable length of a bus system should not exceed 2 meters and the product of the total number of connected test equipment, and the total length of the cable is no more than 20 meters.
- Maximum 15 test equipment can be connected on the same bus at the same time.
- There is no restriction on how the cables are connected together, but it is recommended to stack only 4 back connectors on any test equipment.

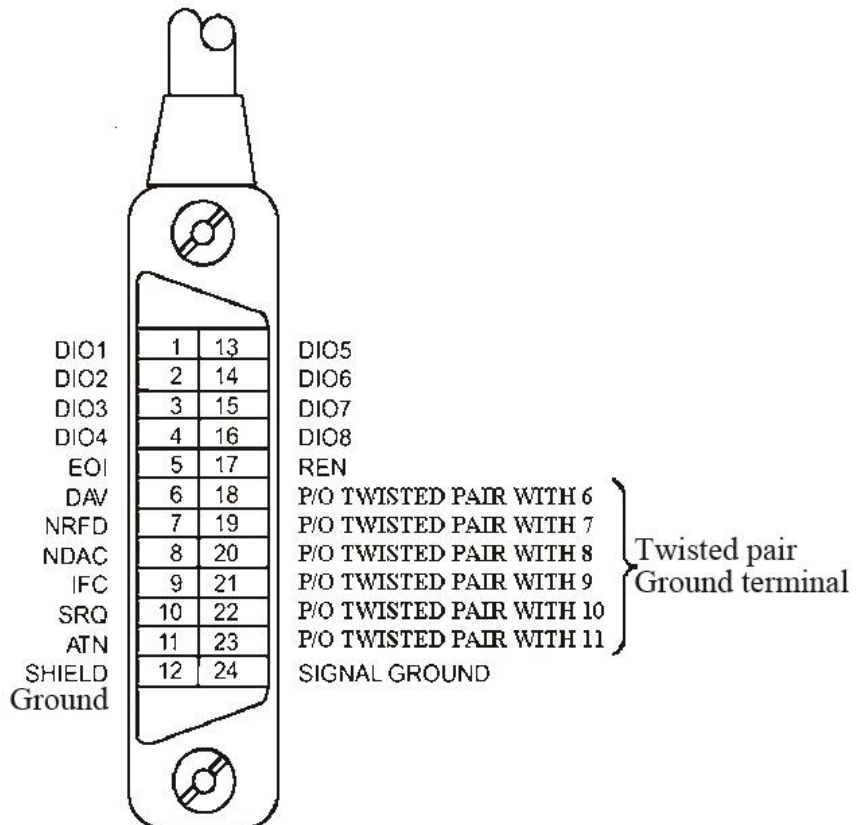

Figure5-1 GPIB Connector/Pin Structure Diagram

GPIB Cable Connection Method #1:

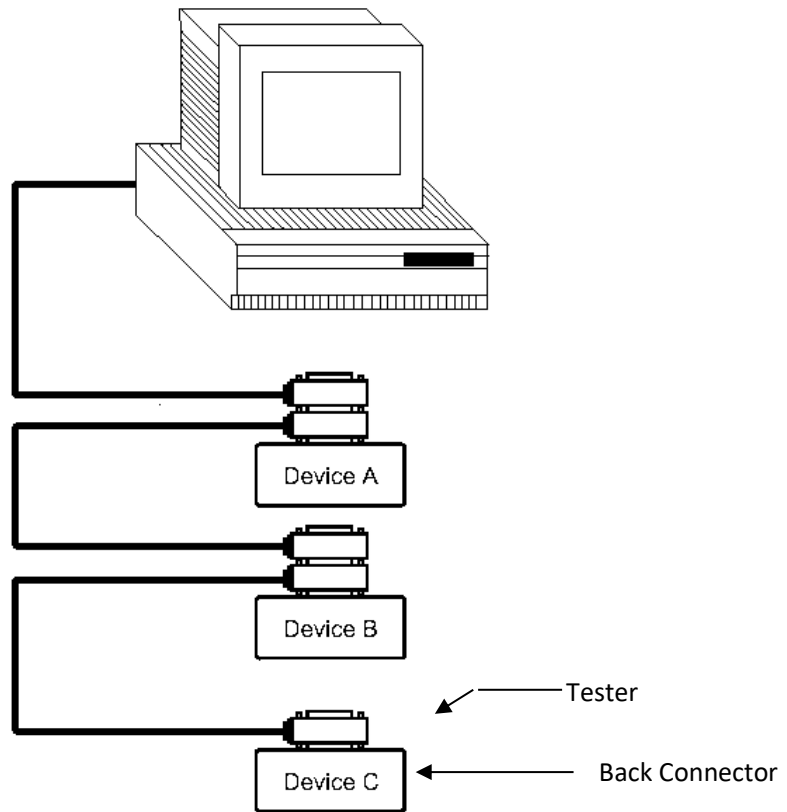

Figure5-2 Double Back Connector Staking

GPIB Cable Connection Method #2:

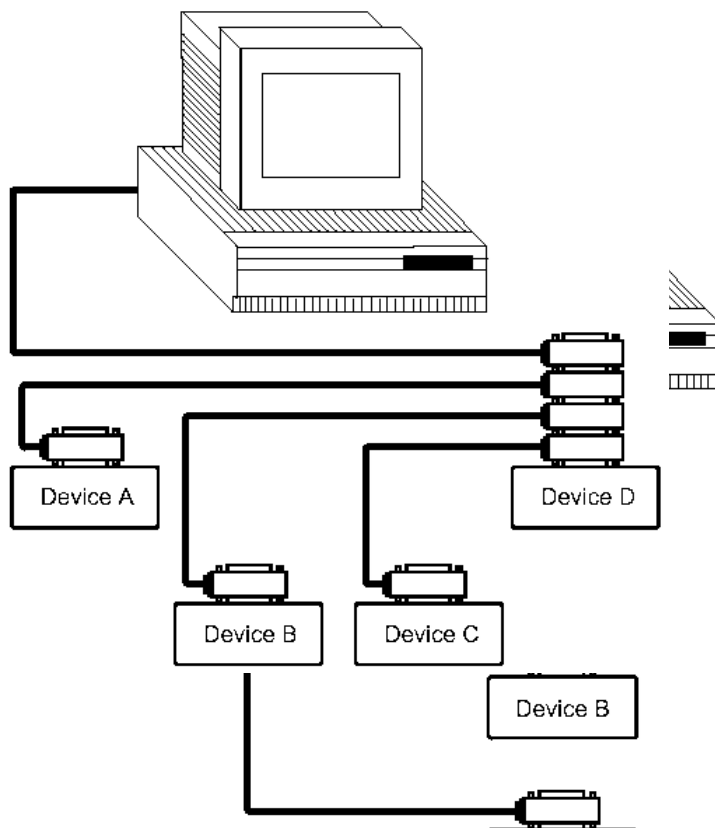

Figure 5-3 Four-Back Connector Stacking

5.1.2.2 GPIB Interface Function

This tester provides most of the general functions of GPIB except the controller, see the following table:

Code	Function
SH1	Support all data source contact functions
AH1	Support all digital panel meter contact functions
T5	Basic talk function; Talk only function; Talking cancelled when MLA; Do not support serial roll call
L4	Basic listen function; Listen cancelled when MTA; No listen only function
RL1	Remote/Local function
DC1	Device clearance function
DT1	Device trigger function
C0	No controller function
E1	Open-collector drive

5.1.2.3 GPIB Address

The GPIB of this tester is addressed by single address, no secondary address, 0-30 can be used as the GPIB address, the factory default address is 1, the address value can be automatically saved in the non-volatile memory. The address setting is as below.

Press **SYSTEM** menu key → (**F3** soft key) → direction key to move the cursor to port format → **GPIB** soft key → direction key to move the cursor to the address number → numeric keypad input address.

5.1.2.4 GPIB Bus Function

The tester can respond to the following GPIB bus commands:

- Interface Clear (IFC)
- Device Clear (SDC or DCL)

After receiving this command, the tester will clear the input and output buffers, and the GPIB interface is in the ready state.

- Local Control (GTL)

This command returns the tester to local control and the keys on the panel are active.

- Local Lock (LLO)

This command makes all the keys on the panel inoperable.

Local Lock can be released after executing the "Local Control" command.

- Remote Control (RMT)

5.2 Serial Port Commands Instruction

Brief Description of the Command Format:

1. The tester commands only describe the actual characters received or sent.
2. Command characters are all ASCII characters.
3. The data "<???" of the command is an ASCII string. The default format of the system is integer or floating point number. The default data unit does not appear in the commands.
4. The command end must have a command end tag, and the default end tag is:
 - a) NL: new line, an integer of 10 (0x0A). An identifier for the end of a command, without this, the tester does not resolve the command.
 - b) ^END: EOI (end) signal of IEEE-488 bus.

Example of Multiple Commands to Simplify Sending:

```
FUNC:SOUR:STEP_1:CAL_0_1500_0_0.01_0.005_0.01_0.005_0_10_0_
    0_0_11_0_50_200_HELLO!_0_0 (NL^END)
```

The numbers and characters separated by spaces after the CAL character respectively indicate: Test Mode (0: AC, 1: DC, 2: IR, 3: PA, 4: OSC); Test Voltage (50~6000;) Test Frequency (0:50Hz, 1:60Hz); High Limit; Low Limit; Arc Limit; Ramp Time; Test Time; Fall Time; Ramp judgment (0: off, 1: on); Ramp Arc; OSC nominal capacitance (11nF); Insulation Resistance Range (0: automatic, 1~6:300nA~10mA); Open Circuit Standard (50%); Short Circuit Standard (200%); PA MESSAGE (HELLO!); DC Waiting Time; PA Time. Regardless of which test function is selected, all parameters need to be fixedly written.

Note: In the above example, "_ " is a space tag.

5.2.1 SCPI Commands

Subsystem commands of TH9110/9110A:

- DISPlay ●FUNction
- SYSTem ●MMEM ●FETC

5.2.2 DISPlay Subsystem Commands

DISPlay subsystem commands are mainly used to set the instrument display page.

The :DISPlay? query returns to the current page.

DISPlay: PAGE

Command Syntax: DISPlay:PAGE <page name>

<page name> are as follows:

TEST	Set the display page to: measurement display page (TEST)
SETUP	Set the display page to: Measurement Setting Page (SETUP)
SYST	Set the display page to: System Setting Page (SYST)

FILE	Set the display page to: File List Page (FILE)
MAIN	Set the display page to: Standby Home Page

Character? can query the current page.

--Example:

Set the display page to measurement display.

Command Syntax: DISP: PAGE TEST

Query syntax: DISPlay:PAGE?

Return format: TEST

Set measurement page display mode: 0, step mode; 1, list mode

Command Syntax: DISP:MODE 0

Query Syntax: DISP:MODE?

Return Format: 0

5.2.3 FUNCTION Subsystem Commands

5.2.3.1 FUNCTION Subsystem Commands

FUNCTION subsystem command is mainly used to set the test parameters of test function.

5.2.3.2 PROG Fuction Commands

FUNC:SOURce:STEP_<sn>:INS Add a new test project to the existing test plan (STEP).

FUNC:SOURce:STEP_<sn>:DEL In the existing test plan (STEP), delete the current test project.

FUNC:SOURce:STEP_<sn>:NEW Create an empty test programm to write a brand new test program.

5.2.3.3 AC Setup Fuction Commands

FUNC:SOURce:STEP:AC:VOLT To set / inquiry about the voltage for ACW test.

--Syntax:

Command message:

FUNC:SOUR:STEP <sn>:AC:VOLT<voltage>

Query message:

FUNC:SOUR:STEP <sn>:AC:VOLT?

--Data<sn>:

Data format: integer

Data range: 1~50

Data accuracy: 1

--Data<voltage>:

Data format: integer

Data range: 50~5000

Data accuracy: 1

Data unit: V

--Example:

Set the voltage for ACW test in STEP1 as 1000V.

Command message: FUNC:SOUR:STEP 1:AC:VOLT 1000

Query message: FUNC:SOUR:STEP 1:AC:VOLT?

Return value: 1000

FUNC:SOURce:STEP:AC:UPPC To set/inquiry about the UPPER current for ACW test.

--Syntax:

Command message:

FUNC:SOUR:STEP <sn>:AC:UPPC<current>

Query message:

FUNC:SOUR:STEP <sn>:AC:UPPC?

--Data<voltage>:

Data format: float

Data range: 0.001~120.000mA (voltage <4000V)

0.001~100.000mA (voltage>4000V)

Data accuracy: 0.001mA

Data unit: mA

--Example:

Set the current for ACW test in STEP1 as 1mA.

Command message: FUNC:SOUR:STEP 1:AC:UPPC 1

Query message: FUNC:SOUR:STEP 1:AC:UPPC?

Return message: 1.000

FUNC:SOURce:STEP:AC:LOWC To set /inquiry about the LOWER current for ACW test.

--Syntax:

Command message:

FUNC:SOUR:STEP <sn>:AC:LOWC<current>

Query message:

FUNC:SOUR:STEP <sn>:AC:LOWC?

--Data<current>:

Data format: float

Data range: 0~UPPER current (0 is OFF)

Data accuracy: 0.001mA

Data unit: mA

--Example:

Set the LOWER current for ACW test in STEP1 as 1mA.

Command message: FUNC:SOUR:STEP 1:AC:LOWC 1

Query message: FUNC:SOUR:STEP 1:AC:LOWC?

Return message: 1.000

FUNC:SOURce:STEP:AC:TTIM To set /inquiry about the TEST time for ACW test.

--Syntax:

Command message:

FUNC:SOUR:STEP <sn>:AC:TTIM<time>

Query message:

FUNC:SOUR:STEP <sn>:AC:TTIM?

--Data<time>:

Data format: float

Data range: 0, 0.3~999.0s (0 is OFF)

Data accuracy: 0.1s

Data unit: s

--Example:

Set the TEST time for ACW test in STEP1 as 1s.

Command message: FUNC:SOUR:STEP 1:AC:TTIM 1

Query message: FUNC:SOUR:STEP 1:AC:TTIM?

Return message: 1.0

FUNC:SOURce:STEP:AC:RTIM To set /inquiry about the RISE time for ACW test.**--Syntax:**

Command message:

FUNC:SOUR:STEP <sn>:AC:RTIM<time>

Query message:

FUNC:SOUR:STEP <sn>:AC:RTIM?

--Data<time>:

Data format: float

Data range: 0~999.9s (0 is OFF)

Data accuracy: 0.1s

Data unit: s

--Example:

Set the RISE time for ACW test in STEP1 as 1s.

Command message: FUNC:SOUR:STEP 1:AC:RTIM 1

Query message: FUNC:SOUR:STEP 1:AC:RTIM?

Return message: 1.0

FUNC:SOURce:STEP:AC:FTIM To set /inquiry about the FALL time for ACW test.**--Syntax:**

Command message:

FUNC:SOUR:STEP <sn>:AC:FTIM<time>

Query message:

FUNC:SOUR:STEP <sn>:AC:FTIM?

--Data<time>:

Data format: float

Data range: 0~999.0s (0 is OFF)

Data accuracy: 0.1s

Data unit: s

--Example:

Set the FALL time for ACW test in STEP1 as 1s.

Command message: FUNC:SOUR:STEP 1:AC:FTIM 1

Query message: FUNC:SOUR:STEP 1:AC:FTIM?

Return message: 1.0

FUNC:SOURce:STEP:AC:ARC To set /inquiry about the ARC upper current for ACW test.

--Syntax:

Command message:

FUNC:SOUR:STEP <sn>:AC:ARC<current>

Query message:

FUNC:SOUR:STEP <sn>:AC:ARC?

--Data<current>:

Data format: float

Data range: 0, 1.0~20.0mA (0 is OFF)

Data accuracy: 0.1mA

Data unit: mA

--Example:

Set the ARC upper current for ACW test in STEP1 as 1mA.

Command message: FUNC:SOUR:STEP 1:AC:ARC 1

Query message: FUNC:SOUR:STEP 1:AC:ARC?

Return message: 1.0

FUNC:SOURce:STEP:AC:FREQ To set /inquiry about the test frequency for ACW test.

--Syntax:

Command message:

FUNC:SOUR:STEP <sn>:AC:FREQ<frequency>

Query message:

FUNC:SOUR:STEP <sn>:AC:FREQ?

--Data<frequency>:

Data format: character

Data range: 50/60

Data unit: Hz

--Example:

Set the test frequency for ACW test in STEP1 as 50Hz.

Command message: FUNC:SOUR:STEP 1:AC:FREQ:50

Query message: FUNC:SOUR:STEP 1:AC:FREQ?

Return message: 50

5.2.3.4 Commands for DC Setup Function

FUNC:SOURce:STEP:DC:VOLT To set /inquiry about the voltage for DCW test.

--Syntax:

Command message: FUNC:SOUR:STEP <sn>:DC:VOLT<voltage>

Query message: FUNC:SOUR:STEP <sn>:DC:VOLT?

--Data<sn>:

Data format: integer

Data range: 1~50

Data accuracy: 1

--Data<voltage>:

Data format: float

Data range: 50~6000

Data accuracy: 1

Data unit: V

--Example:

Set the voltage for DCW test in STEP1 to 1000V

Command message: FUNC:SOUR:STEP 1:DC:VOLT 1000

Query message: FUNC:SOUR:STEP 1:DC:VOLT?

Return value: 1000

FUNC:SOURce:STEP:DC:UPPC To set /inquiry about the UPPER current for DCW test.**--Syntax:**

Command message: FUNC:SOUR:STEP <sn>:DC:UPPC <current>

Query message: FUNC:SOUR:STEP <sn>:DC:UPPC?

--Data<current>:

Data format: float

Data range: 0.0001~25.000mA (voltage>=1500V)

0.0001~20.000mA (voltage<1500V)

Data accuracy: 0.0001mA

Data unit: mA

--Example:

Set the upper current for DCW test in STEP1 to 1mA

Command message: FUNC:SOUR:STEP 1:DC:UPPC 1

Query message: FUNC:SOUR:STEP 1:DC:UPPC?

Return value: 1.000

FUNC:SOURce:STEP:DC:LOWC To set /inquiry about the LOWER current for DCW test.**--Syntax:**

Command message: FUNC:SOUR:STEP <sn>:DC:LOWC<current>

Query message: FUNC:SOUR:STEP <sn>:DC:LOWC?

--Data<current>:

Data format: float

Data range: 0~upper current (0 is OFF)

Data accuracy: 0.0001mA

Data unit: mA

--Example:

Set the lower current for DCW test in STEP1 to 1mA

Command message: FUNC:SOUR:STEP 1:DC:LOWC 1

Query message: FUNC:SOUR:STEP 1:DC:LOWC?

Return value: 1.000

FUNC:SOURce:STEP:DC:TTIM To set /inquiry about the TEST time for DCW test.

--Syntax:

Command message: FUNC:SOUR:STEP <sn>:DC:TTIM<time>

Query message: FUNC:SOUR:STEP <sn>:DC:TTIM?--Data<time>:

--Data format: float

Data range: 0, 0.3~999.0s (0 is OFF)

Data accuracy: 0.1s

Data unit: s

--Example:

Set the test time for DCW test in STEP1 to 1s

Command message: FUNC:SOUR:STEP 1:DC:TTIM 1

Query message: FUNC:SOUR:STEP 1:DC:TTIM?

Return value: 1.0

FUNC:SOURce:STEP:DC:RTIM To set /inquiry about the RISE time for DCW test.

--Syntax:

Command message: FUNC:SOUR:STEP <sn>:DC:RTIM<time >

Query message: FUNC:SOUR:STEP <sn>:DC:RTIM?

--Data<time>:

Data format: float

Data range: 0~999.0s (0 is OFF)

Data accuracy: 0.1s

Data unit: s

--Example:

Set the rise time for DCW test in STEP1 to 1s

Command message: FUNC:SOUR:STEP 1:DC:RTIM 1

Query message: FUNC:SOUR:STEP 1:DC:RTIM?

Return value: 1.0

FUNC:SOURce:STEP:DC:FTIM To set /inquiry about the FALL time for DCW test.

--Syntax:

Command message: FUNC:SOUR:STEP <sn>:DC:FTIM<time>

Query message: FUNC:SOUR:STEP <sn>:DC:FTIM?

--Data<time>:

Data format: float

Data range: 0~999.0s (0 is OFF)

Data accuracy: 0.1s

Data unit: s

--Example:

Set the fall time for DCW test in STEP1 to 1s

Command message: FUNC:SOUR:STEP 1:DC:FTIM 1

Query message: FUNC:SOUR:STEP 1:DC:FTIM?

Return value: 1.0

FUNC:SOURce:STEP:DC:WTIM To set /inquiry about the wait time for DCW test.

--Syntax:

Command message:

FUNC:SOUR:STEP <sn>:DC:WTIM<time>

Query message:

FUNC:SOUR:STEP <sn>:DC:WTIM?

--Data<time>:

Data format: float

Data range: 0~999.0s (0 is OFF)

Data accuracy: 0.1s

Data unit: s

--Example:

Set the wait time for DCW test in STEP1 as 1s.

Command message: FUNC:SOUR:STEP 1:DC:WTIM 1

Query message: FUNC:SOUR:STEP 1:DC:WTIM?

Return message: 1.0

FUNC:SOURce:STEP:DC:ARC To set /inquiry about the ARC upper current for DCW test.

--Syntax:

Command message: FUNC:SOUR:STEP <sn>:DC:ARC<current >

Query message: FUNC:SOUR:STEP <sn>:DC:ARC?

--Data<current>:

Data format: float

Data range: 0, 1.0~10.0mA (0 is OFF)

Data accuracy: 0.1mA

Data unit: mA

--Example:

Set the ARC upper current for DCW test in STEP1 to 1mA

Command message: FUNC:SOUR:STEP 1:DC:ARC 1

Query message: FUNC:SOUR:STEP 1:DC:ARC?

Return value: 1.0

FUNC:SOURce:STEP:DC:RAMPARC To set /inquiry about the RAMP ARC for DCW test.

--Syntax:

Command message:

FUNC:SOUR:STEP <sn>:DC:RAMPARC<current>

Query message:

FUNC:SOUR:STEP <sn>:DC:RAMPARC?

--Data<voltage>:

Data format: float

Data range: 0, 1.0~10.0mA (0 is OFF)

Data accuracy: 0.1mA

Data unit: mA

--Example:

Set the RAMP arc for DCW test in STEP1 to 1mA.

Command message: FUNC:SOUR:STEP 1:DC:RAMPARC 1

Query message: FUNC:SOUR:STEP 1:DC:RAMPARC?

Return message: 1.0

FUNC:SOURce:STEP:DC:RAMP To set /inquiry about the RAMP state for DCW test.

--Syntax:

Command message:

FUNC:SOUR:STEP <sn>:DC:RAMP<ON/OFF>or<1/0>

Query message:

FUNC:SOUR:STEP <sn>:DC:RAMP?

--Data<voltage>:

Data format: character

Data range: OFF(0), ON(1)

--Example:

Set the RAMP state for DCW test in STEP1 to ON.

Command message: FUNC:SOUR:STEP 1:DC:RAMP ON

Query message: FUNC:SOUR:STEP 1:DC:RAMP?

Return message: 1

5.2.3.5 Commands for IR Setup Function

FUNC:SOURce:STEP:IR:VOLT To set /inquiry about the voltage for IR test.

--Syntax:

Command message: FUNC:SOUR:STEP <sn>:IR:VOLT<voltage >

Query message: FUNC:SOUR:STEP <sn>:IR:VOLT?

--Data<voltage>:

Data format: float

Data range: 50~1000

Data accuracy: 1

Data unit: V

--Example:

Set the voltage for IR test in STEP1 to 1000V.

Command message: FUNC:SOUR:STEP 1:IR:VOLT 1000

Query message: FUNC:SOUR:STEP 1:IR:VOLT?

Return value: 1000

FUNC:SOURce:STEP:IR:UPPC To set /inquiry about the UPPER resistance for IR test.

--Syntax:

Command message FUNC:SOUR:STEP<sn>:IR:UPPR <resistance >

Query message: FUNC:SOUR:STEP <sn>:IR:UPPR?

--Data< resistance>:

Data format: float

Data range: 0, lower limit~50.0GΩ (0 is OFF)

Data accuracy: 1.0 MΩ

Data unit: MΩ

--Example:

Set the upper resistance for IR test in STEP1 to 1 MΩ.

Command message: FUNC:SOUR:STEP 1:IR:UPPR 1

Query message: FUNC:SOUR:STEP 1:IR:UPPR?

Return value: 1

FUNC:SOURce:STEP:IR:LOWR To set /inquiry about the LOWER resistance for IR test.

--Syntax:

Command message: FUNC:SOUR:STEP <sn>:IR:LOWR<resistance >

Query message: FUNC:SOUR:STEP <sn>:IR:LOWR?

--Data<resistance>:

Data format: float

Data range: 0.1MΩ~50.0GΩ

Data accuracy: 0.1 MΩ

Data unit: MΩ

--Example:

Set the lower resistance for IR test in STEP1to 1 MΩ.

Command message: FUNC:SOUR:STEP 1:IR:LOWR 1

Query message: FUNC:SOUR:STEP 1:IR:LOWR?

Return value: 1

FUNC:SOURce:STEP:IR:TTIM To set /inquiry about the TEST time for IR test.

--Syntax:

Command message: FUNC:SOUR:STEP <sn>:IR:TTIM<time>

Query message: FUNC:SOUR:STEP <sn>:IR:TTIM?

--Data<time>:

Data format: float

Data range: 0, 0.3~999.0s (0 is OFF)

Data accuracy: 0.1s

Data unit: s

--Example:

Set the test time for IR test in STEP1 to 1s.

Command message: FUNC:SOUR:STEP 1:IR:TTIM 1

Query message: FUNC:SOUR:STEP 1:IR:TTIM?

Return value: 1.0

FUNC:SOURce:STEP:IR:RTIM To set /inquiry about the RISE time for IR test.

--Syntax:

Command message: FUNC:SOUR:STEP <sn>:IR:RTIM<time>

Query message: FUNC:SOUR:STEP <sn>:IR:RTIM?

--Data<time>:

Data format: float

Data range: 0~999.0s (0 is OFF)

Data accuracy: 0.1s

Data unit: s

--Example:

Set the rise time for IR test in STEP1 to 1s.

Command message: FUNC:SOUR:STEP 1:IR:RTIM 1

Query message: FUNC:SOUR:STEP 1:IR:RTIM?

Return value: 1.0

FUNC:SOURce:STEP:IR:FTIM To set /inquiry about the FALL time for IR test.

--Syntax:

Command message: FUNC:SOUR:STEP <sn>:IR:FTIM<time>

Query message: FUNC:SOUR:STEP <sn>:IR:FTIM?

--Data<time>:

Data format: float

Data range: 0~999.0s (0 is OFF)

Data accuracy: 0.1s

Data unit: s

--Example:

Set the fall time for IR test in STEP1 to 1s.

Command message: FUNC:SOUR:STEP 1:IR:FTIM 1

Query message: 1.0

FUNC:SOURce:STEP:IR:RANG To set /inquiry about the range for IR test.

--Syntax:

Command message: FUNC:SOUR:STEP <sn>:IR:RANG<range>

Query message: FUNC:SOUR:STEP <sn>:IR:RANG?

--Data<range>:

Data format: integer

Data range: 0~6 (0 is AUTO, 1 is 10mA, 2 is 3mA, 3 is 300uA, 4 is 30uA, 5 is 3uA, 6 is 300nA)

--Example:

Set the range for IR test in STEP1 to 10mA.

Command message: FUNC:SOUR:STEP 1:IR:RANG 1

Query message: FUNC:SOUR:STEP 1:IR:RANG?

Return value: 1

5.2.3.6 Commands for PA Setup Function

FUNC:SOURce:STEP:PA:MESSAge To set /inquiry about the PA message.

--Syntax:

Command message: FUNC:SOUR:STEP <sn>:PA:MESSAge <message >

Query message: FUNC:SOUR:STEP <sn>:PA:MESSAge?

--Data<message>:

Data format: characters

--Example:

Set the PA message in STEP1 to HELLO!

Command message: FUNC:SOUR:STEP 1:PA:MESSAge HELLO!

Query message: FUNC:SOUR:STEP 1:PA:MESSAge?

Return value: HELLO!

FUNC:SOURce:STEP:PA:TIME To set /inquiry about the PA state continue time.

--Syntax:

Command message: FUNC:SOUR:STEP <sn>:PA:TIME<time>

Query message: FUNC:SOUR:STEP <sn>:PA:TIME?

--Data<time>:

Data format: float

Data range: 0, 0.3~999.0s (0 is continue)

Data accuracy: 0.1s

Data unit: s

--Example:

Set the PA continue time in STEP1 to 1s.

Command message: FUNC:SOUR:STEP 1: PA:TIME 1

Query message: FUNC:SOUR:STEP 1: PA:TIME?

Return value: 1.0

5.2.3.7 Commands for OSC Setup Function

FUNC:SOURce:STEP:OS:OPEN To set /inquiry about the OPEN rate for OS test.

--Syntax:

Command message:

FUNC:SOUR:STEP <sn>:OS:OPEN<rate>

Query message:

FUNC:SOUR:STEP <sn>:OS:OPEN?

--Data<rate>:

Data format: integer

Data range: 10~100

Data accuracy: 10

Data unit:

--Example:

Set the OPEN rate for OS test in STEP1 as 50%.

Command message: FUNC:SOUR:STEP 1:OS:OPEN 50

Query message: FUNC:SOUR:STEP 1:OS:OPEN?

Return value: 50

FUNC:SOURce:STEP:OS:SHOT To set /inquiry about the SHOT rate for OS test.

--Syntax:

Command message:

FUNC:SOUR:STEP <sn>:OS:SHOT<rate>

Query message:

FUNC:SOUR:STEP <sn>:OS:SHOT?

--Data< rate>:

Data format: integer

Data range: 0, 100~500 (0 is OFF)

Data accuracy: 10

Data unit:

--Example:

Set the SHOT rate for OS test in STEP1 as 100%.

Command message: FUNC:SOUR:STEP 1:OS:SHOT 100

Query message: FUNC:SOUR:STEP 1:OS:SHOT?

Return value: 100

FUNC:SOURce:STEP:OS:GET Outputs the capacitance.

--Syntax:

Command message:

FUNC:SOUR:STEP <sn>:OS: GET

The instrument will automatically sample the standard capacitance value after impedance transformation of the current.

FUNC:SOURce:STEP:OS:STAND To set /inquiry about the STANDARD capacitance for OS test.

--Syntax:

Command message: FUNC:SOUR:STEP <sn>:OS:STAND<standard capacitance >

Query message: FUNC:SOUR:STEP <sn>:OS: STAND?

--Data< standard capacitance >:

Data format: float

Data range: 0.001~40.000

Data accuracy: 0.001

Data unit: nF

--Example:

Set the standard capacitance for OS test in STEP1 to 10nF.

Command message: FUNC:SOUR:STEP 1:OS:STAND 10

Query message: FUNC:SOUR:STEP 1:OS: STAND?

Return value: 10.000

5.2.3.8 Commands for CK Setup Function

FUNC:SOURce:STEP:CK:VOLT Set/Query CK's voltage

--Syntax:

Command message : FUNC:SOUR:STEP
<sn>:CK:VOLT<voltage>

Query message: FUNC:SOUR:STEP <sn>:CK:VOLT?

--Data<sn>:

Data format: integer

Data range: 1~50

Data accuracy: 1

--Data<Voltage>:

Data format: float

Data range: 100~500

Data accuracy: 1

Data unit: V

--Example:

Set the CK voltage of STEP 1 as: 100V

Command message: FUNC:SOUR:STEP 1:CK:VOLT 100

Query message: FUNC:SOUR:STEP 1:CK:VOLT?

Return Value: 100

FUNC:SOURce:STEP:CK:LOWC Set/Query CK's low current

--Syntax:

:

Command message: FUNC:SOUR:STEP <sn>:CK:LOWC<current>

Query message: FUNC:SOUR:STEP <sn>:CK:LOWC?

--Data<current>:

Data format: float

Data Range: 0.001~5mA

Data Accuracy: 0.001mA

Data Unit: mA

--Example:

Set the CK's low current of STEP 1 as: 0.5mA

Command message: FUNC:SOUR:STEP 1:CK:LOWC 0.5

Query message: FUNC:SOUR:STEP 1:CK:LOWC?

Return Vale: 0.5

5.2.3.9 Commands for BREAKDOWN VOLT Function

FUNC:BREAKdown:STEPMODE To set /inquiry about the STEP MODE for voltage breakdown test.

--Syntax:

Command message: FUNC:BREAK:STEPMODE<step mode >

Query message: FUNC: :BREAK: STEPMODE?

--Data<step mode>:

Data format: integer

Data range: 0 ~ 1 (0: normal step; 1: voltage step)

--Example:

Set the step mode for breakdown test to 1 (voltage step).

Command message: FUNC:BREAK:STEPMODE 1

Query message: FUNC: BREAK: STEPMODE?

Return value: 1

FUNC: BREAKdown: STEP To set /inquiry about the STEP for voltage breakdown test.

--Syntax:

Command message: FUNC: BREAK: STEP<step>

Query message: FUNC: :BREAK: STEP?

--Data<step>:

Data format: integer

Data range: 2~999

Data accuracy: 1

--Example:

Set the step for breakdown test: 55

Command message: FUNC: :BREAK: STEP 55

Query message: FUNC: :BREAK: STEP?

Return value: 55

FUNC: BREAKdown: STEPVOLT To set /inquiry about the STEP VOLTAGE for voltage breakdown test .

--Syntax:

Command message: FUNC: BREAK: STEOVOLT<step voltage >

Query message: FUNC: :BREAK: STEOVOLT?

--Data<step voltage >:

Data format: float

Data range: 5~500

Data accuracy: 1

Data unit: V

--Example:

Set the step voltage for breakdown test to 50V.

Command message: FUNC: BREAK: STEOVOLT 50

Query message: FUNC: BREAK: STEOVOLT?

Return value: 50

FUNC: BREAKdown: MODE To set /inquiry about the MODE for voltage breakdown test.

--Syntax:

Command message: FUNC: BREAK: MODE<test mode>

Query message: FUNC: :BREAK: MODE?

--Data<mode>:

Data format: integer

Data range: 0 ~ 1 (0: AC; 1: DC)

--Example:

Set the mode for breakdown test: 1 (DC)

Command message: FUNC: BREAK: MODE 1

Query message: FUNC: BREAK: MODE?

Return value: 1

FUNC: BREAKdown: VOLTStart To set /inquiry about the VOLTAGE START for voltage breakdown test.

--Syntax:

Command message: FUNC:BREAK:VOLTS<voltage >

Query message: FUNC: :BREAK:VOLTS?

--Data<voltage>:

Data format: float

Data range: 50~5000

Data accuracy: 1

Data unit: V

--Example:

Set the starting voltage for breakdown test to 1000V.

Command message: FUNC:BREAK:VOLTS 1000

Query message: FUNC:BREAK:VOLTS?

Return value: 1000

FUNC:BREAKdown:VOLTEnd To set /inquiry about the VOLTAGE END for voltage breakdown test.

--Syntax:

Command message: FUNC:BREAK:VOLTE<voltage>

Query message: FUNC: :BREAK:VOLTE?

--Data<voltage>:

Data format: float

Data range: 50~5000

Data accuracy: 1

Data unit: V

--Example:

Set the ending voltage for breakdown test to 5000V.

Command message: FUNC:BREAK:VOLTE 5000

Query message: FUNC:BREAK:VOLTE?

Return value: 5000

FUNC: BREAKdown:UPPC To set /inquiry about the HIGH CURRENT for voltage breakdown test.

--Syntax:

Command message: FUNC:BREAK:UPPC <current>

Query message: FUNC:BREAK:UPPC?

--Data<current>:

Data format: float

Data range: 0.0001~25mA (DC); 0.001~100mA (AC)

Data accuracy: 0.0001mA (DC); 0.001mA (AC)

Data unit: mA

--Example:

Set the upper current for breakdown test to 10mA.

Command message: FUNC:BREAK:UPPC 10

Query message: FUNC:BREAK:UPPC?

Return value: 10.000

FUNC: BREAKdown:LOWC To set /inquiry about the LOW CURRENT for voltage breakdown test.

--Syntax:

Command message: FUNC:BREAK:LOWC<current>

Query message: FUNC:BREAK:LOWC?

--Data<current>:

Data format: float

Data range: 0~upper current (0 is OFF)

Data accuracy: 0.0001mA (DC); 0.001mA (AC)

Data unit: mA

--Example:

Set the lower current for breakdown test to 1mA.

Command message: FUNC:BREAK:LOWC 1

Query message: FUNC:BREAK:LOWC?

Return value: 1.000

FUNC: BREAKdown:TTIM To set /inquiry about the TEST TIME for voltage breakdown test.

--Syntax:

Command message: FUNC:BREAK:TTIM<time>

Query message: FUNC:BREAK:TTIM?

--Data<time>:

Data format: float

Data range: 0, 0.3~999.0s (0 is OFF)

Data accuracy: 0.1s

Data unit: s

--Example:

Set the test time for breakdown test to 1s.

Command message: FUNC:BREAK:TTIM 1

Query message: FUNC:BREAK:TTIM?

Return value: 1.0

FUNC: BREAKdown:RTIM To set /inquiry about the RISE TIME for voltage breakdown test.

--Syntax:

Command message: FUNC:BREAK:RTIM<time>

Query message: FUNC:BREAK:RTIM?

--Data<time>:

Data format: float

Data range: 0~999.0s (0 is OFF)

Data accuracy: 0.1s

Data unit: s

--Example:

Set the rise time for breakdown test to 1s.

Command message: FUNC:BREAK:RTIM 1

Query message: FUNC:BREAK:RTIM?

Return value: 1.0

FUNC: BREAKdown:WTIM To set /inquiry about the WAIT TIME for voltage breakdown test.

--Syntax:

Command message: FUNC:BREAK:WTIM<time>

Query message: FUNC:BREAK:WTIM?

--Data<time>:

Data format: float

Data range: 0~999.0s (0 is OFF)

Data accuracy: 0.1s

Data unit: s

--Example:

Set the waiting time for breakdown test to 1s.

Command message: FUNC:BREAK:WTIM 1

Query message: FUNC:BREAK:WTIM?

Return value: 1.0

FUNC:BREAK:ARC To set /inquiry about the ARC high current for voltage breakdown test.

--Syntax:

Command message: FUNC:BREAK:ARC<current >

Query message: FUNC:BREAK:ARC?

--Data<current>:

Data format: float

Data range: 0, 1.0~10.0mA (DC), 1.0 ~ 20mA (AC) (0 is OFF)

Data accuracy: 0.1mA

Data unit: mA

--Example:

Set the arc upper current for breakdown test to 5mA.

Command message: FUNC:BREAK:ARC 5

Query message: FUNC:BREAK:ARC?

Return value: 5.0

FUNC:BREAKdown:CONTINUE To set /inquiry about the CONTINUE ON OFF for voltage breakdown test.

--Syntax:

Command message: FUNC:BREAK:CONT<ON OFF>

Query message: FUNC: :BREAK: CONT?

--Data<ON OFF>:

Data format: integer

Data range: 0, 1 (0: OFF; 1: ON)

--Example:

Set the continue test on off for breakdown test to 1(ON).

Command message: FUNC:BREAK: CONT 1

Query message: FUNC:BREAK: CONT?

Return value: 1

FUNC:BREAKdown:SAVE To SAVE the setting for breakdown test.

--Example:

Save the setting for breakdown test

Command message: FUNC:BREAK: SAVE

5.2.4 SYSTEM Subsystem Commands

5.2.4.1 Commands for MEA Setup Function

SYSTEM:MEA:TRGMODE To set /inquiry about the TRIGGER MODE for test.

--Syntax:

Command message: SYSTEM:MEA:TRGMODE<mode>

Query message: SYSTEM:MEA:TRGMODE ?

--Data<mode>:

Data format: characters

Data range: 0~3 (0: manual, 1:external, 2:bus, 3:auto)

--Example:

Set the trigger mode to manual.

Command message: SYSTEM:MEA:TRGMODE 0

Query message: SYSTEM:MEA:TRGMODE ?

Return value: 0

SYSTEM:MEA:TRGDLY To set /inquiry about the TRIGGER DELAY for test.

--Syntax:

Command message: SYSTEM:MEA:TRGDLY<time>

Query message: SYSTEM:MEA:TRGDLY ?

--Data<time>:

Data format: float

Data range: 0.0~99.9s

Data accuracy: 0.1s

Data unit: s

--Example:

Set the trigger delay to 1.0s.

Command message: SYSTEM:MEA:TRGDLY 1.0

Query message: SYSTEM:MEA:TRGDLY ?

Return value: 1.0

SYSTEM:MEA:MEAMODE To set /inquiry about the MEASURE MODE for test.

--Syntax:

Command message: SYSTem:MEA:MEAMODE<mode>

Query message: SYSTem:MEA:MEAMODE ?

--Data<mode>:

Data format: characters

Data range: 0~2 (0:normal, 1:repeat, 2:cycle)

--Example:

Set the measurement mode to normal.

Command message: SYSTem:MEA:MEAMODE 0

Query message: SYSTem:MEA:MEAMODE ?

Return value: 0

SYSTem:MEA:RPTCNT To set /inquiry about the REPEAT COUNT for test.

--Syntax:

Command message: SYSTem:MEA:RPTCNT<count >

Query message: SYSTem:MEA:RPTCNT ?

-Data<count>:

Data format: integer

Data range: 0~999

Data accuracy: 1

--Example:

Set the repeat count to 2.

Command message: SYSTem:MEA:RPTCNT 2

Query message: SYSTem:MEA:RPTCNT ?

Return value: 2

SYSTem:MEA:RPTINT To set /inquiry about the REPEAT INTERVAL for test.

--Syntax:

Command message: SYSTem:MEA:RPTINT <time>

Query message: SYSTem:MEA:RPTINT ?

--Data<time>:

Data format: float

Data range: 0.0~99.9s

Data accuracy: 0.1s

Data unit: s

--Example:

Set the test interval to 1.0s.

Command message: SYSTem:MEA:RPTINT 1.0

Query message: SYSTem:MEA:RPTINT ?

Return value: 1.0

SYSTem:MEA:AFTERFAIL To set /inquiry about the AFTER FAIL status.

--Syntax:

Command message: SYSTem:MEA:AFTERFAIL<status >

Query message: SYSTem:MEA:AFTERFAIL ?

--Data<mode>:

Data format: characters

Data range: 0~2 (0:continue, 1:repeat, 2:stop)

--Example:

Set the after fail status to continue.

Command message: SYSTem:MEA:AFTERFAIL 0

Query message: SYSTem:MEA:AFTERFAIL ?

Return value: 0

SYSTem:MEA:PASSHOLD To set /inquiry about the beep response time for PASS HOLD.

--Syntax:

Command message: SYSTem:MEA:PASSHOLD <time>

Query message: SYSTem:MEA:PASSHOLD ?

--Data<time>:

Data format: float

Data rang: 0.2~99.9s

Data accuracy: 0.1s

Data unit: s

--Example:

Set the pass hold beep response time to1.0s.

Command message: SYSTem:MEA:PASSHOLD 1.0

Query message: SYSTem:MEA:PASSHOLD ?

Return value: 1.0

SYSTem:MEA:STEPHOLD To set /inquiry about interval for STEP HOLD.

--Syntax:

Command message: SYSTem:MEA:STEPHOLD <time>

Query message: SYSTem:MEA:STEPHOLD ?

--Data<time>:

Data format: float

Data range: 0.1~99.9s, KEY

Data accuracy: 0.1s

Data unit: s

--Example:

Set the step hold interval to 1.0s.

Command message: SYSTem:MEA:STEPHOLD 1.0

Query message: SYSTem:MEA:STEPHOLD ?

Return value: 1.0

SYSTem:MEA:HARDAGC To set /inquiry about HARDWARE COMPENSATION status.

--Syntax:

Command message: SYSTem:MEA:HARDAGC <ON/OFF>or<1/0>

Query message: SYSTem:MEA:HARDAGC?

--Data<ON/OFF>:

Data format: characters

Data range: OFF(0), ON (1)

--Example:

Set the hardware compensation to ON.

Command message: SYSTem:MEA:HARDAGC ON

Query message: SYSTem:MEA:HARDAGC?

Return value: ON

SYSTem:MEA:SOFTAGC To set /inquiry about SOFTWARE COMPENSATION status.

--Syntax:

Command message: SYSTem:MEA:SOFTAGC <ON/OFF>or<1/0>

Query message: SYSTem:MEA:SOFTAGC?

--Data<ON/OFF>:

Data format: characters

Data range: OFF (0), ON (1)

--Example:

Set the software compensation to ON.

Command message: SYSTem:MEA:SOFTAGC ON

Query message: SYSTem:MEA:SOFTAGC?

Return value: ON

SYSTem:MEA:AUTORANGE To set /inquiry about AUTO RANGE status.

-Syntax:

Command message: SYSTem:MEA:AUTORANGE <ON/OFF>or<1/0>

Query message: SYSTem:MEA:AUTORANGE?

--Data<ON/OFF>:

Data format: characters

Data range: OFF (0), ON (1)

--Example:

Set the auto rang to ON.

Command message: SYSTem:MEA:AUTORANGE 1

Query message: SYSTem:MEA:AUTORANGE?

Return value: 1

SYSTem:MEA:GFI To set /inquiry about the state for GFI.

--Syntax:
 Command message: SYSTem:MEA:GFI <ON/OFF/FLOAT>or<1/0/2>
 Query message: SYSTem:MEA:GFI?
 --Data<ON/OFF/FLOAT>:
 Data format: characters
 Data range: OFF (0), ON (1), FLOAT (2)
 --Example:
 Set GFI to 1.
 Command message: SYSTem:MEA:GFI 1
 Query message: SYSTem:MEA:GFI?
 Return value: 1

5.2.4.2 Commands for ENV Setup Function

SYSTem:ENV:KEYVOL To set /inquiry about the state for KEY VOLUME.

--Syntax:
 Command message: SYSTem:ENV:KEYVOL <ON/OFF>or<1/0>
 Query message: SYSTem:ENV:KEYVOL?
 --Data<ON/OFF>:
 Dataformat: characters
 Data range: OFF (0), ON (1)
 --Example:
 Set the key sound volume state to ON.
 Command message: SYSTem:ENV:KEYVOL 1
 Query message: SYSTem:ENV:KEYVOL?
 Return value: 1

SYSTem:ENV:BEEPVOL To set /inquiry about the state for BEEP VOLUME.

--Syntax:
 Command message: SYSTem:ENV:BEEPVOL <volume>
 Query message: SYSTem:ENV:BEEPVOL?
 --Data<volume>:
 Data format: characters
 Data range: 0~3 (0:OFF1:LOW, 2:MED, 3:HIGH)
 --Example:
 Set the beeper sound volume to HIGH.
 Command message: SYSTem:ENV:BEEPVOL 3
 Query message: SYSTem:ENV:BEEPVOL?
 Return value: 3

SYSTem:ENV:PASSVOL To set /inquiry about the state for PASS VOLUM.

--Syntax:

Command message: SYSTem:ENV:PASSVOL <ON/OFF>or<1/0>

Query message: SYSTem:ENV:PASSVOL?

--Data<ON/OFF>:

Dataformat: characters

Data range: OFF (0), ON (1)

--Example:

Set the pass volume to ON.

Command message: SYSTem:ENV:PASSVOL 1

Query message: SYSTem:ENV:PASSVOL?

Return value: 1

SYSTem:ENV:FAILVOL To set /inquiry about the state for FAIL VOLUM

--Syntax:

Command message: SYSTem:ENV:FAILVOL <ON/OFF>or<1/0>

Query messa: SYSTem:ENV:FAILVOL?

--Data<ON/OFF>:

Data format: characters

Data range: OFF (0), ON (1)

--Example:

Set fail volume to ON.

Command message: SYSTem:ENV:FAILVOL 1

Query message: SYSTem:ENV:FAILVOL?

Return value: 1

SYSTem:ENV:LANGUage To set /inquiry about the state for LANGUAGE.

--Syntax:

Command message: SYSTem:ENV:LANGUage <1/0>

Query message: SYSTem:ENV:LANGUage?

--Data<1/0>:

Dataformat: characters

Data range: 0 (Chinese), 1 (English)

--Example:

Set the language state to Chinese.

Command message: SYSTem:ENV:LANGUage 0

Query message: SYSTem:ENV:LANGUage?

Return value: 0

SYSTem:ENV:KEYLOCK To set /inquiry about the state for KEY LOCK.

--Syntax:

Command message: SYSTem:ENV:KEYLOCK <state>

Query message: SYSTem:ENV:KEYLOCK?

--Data<state>:

Data format: characters

Data range: 0/1(0: manual, 1: bus)

--Example:

Set key lock state to manual.

Command message: SYSTem:ENV:KEYLOCK 0

Query message: SYSTem:ENV:KEYLOCK?

Return value: 0

SYSTem:ENV:KEYLOCK:UNLOCK To set /inquiry about the state for UNLOCK.

--Example:

Release the button lock status under the bus unlock setting condition

Command message: SYSTem:ENV:KEYLOCK:UNLOCK

SYSTem:ENV:BRiGht To set /inquiry about the state for backlight BRIGHT.

--Syntax:

Command message: SYSTem:ENV:BRiGht <brightness>

Query message: SYSTem:ENV:BRiGht?

--Data<brightness>:

Data format: integer

Data range: 1~10

--Example:

Set the backlight brightness to 5.

Command message: SYSTem:ENV:BRiGht 5

Query message: SYSTem:ENV:BRiGht?

Return value: 5

SYSTem:ENV:DATE To set /inquiry about the system DATE.

--Syntax:

Command message: SYSTem:ENV:DATE <year month date>

Query message: SYSTem:ENV:DATE?

--Data<year month date>:

Data format: characters

Data range: 2017 1 1~9999 12 31

--Example:

Set the system date to 2017 11 17.

Command message: SYSTem:ENV:DATE 2017 11 17

Query message: SYSTem:ENV:DATE?

Return value: 2017,11,17

SYSTem:ENV:TIME To set /inquiry about the system TIME.

--Syntax:

Command message: SYSTem:ENV:TIME <hour minute second>

Query message: SYSTem:ENV:TIME?

--Data< hour minute second >:

Dataformat: characters

Data range: 0 0 0 ~ 23 59 59

--Example:

Set the system time to 16 23 23.

Command message: SYSTem:ENV:TIME 16 23 23

Query message: SYSTem:ENV:TIME?

Return value: 16, 23, 23

5.2.5 MMEM Subsystem Commands

MMEM:SAVE SAVE the current settings to a file stored internally as

<filename>.

--Syntax:

Command messag: MMEM:SAVE <file name>

--Data<file name>:

Data format: characters

Return value: OK

--Example:

Set save file name: TH9110TEST

Command message: MMEM:SAVE TH9110TEST

MMEM:LOAD LOAD the internal file specified by the file name

to the current.

--Syntax:

Command message: MMEM:LOAD <file>

--Data<file>:

Data format: characters

--Example:

Set the load file name to TH9110TEST.

Command message: MMEM:LOAD TH9110TEST

Return value: load pass return OK, load fail return ERROR

MMEM:DEL DELETE the internal file specified by the file name.

--Syntax:

Command message: MMEM:DEL <file name>

--Data<file name>:

Data format: characters

--Example:

Set delete file name to TH9110TEST.

Command message: MMEM:DEL TH9110TEST

Return value: delete pass return OK, delete fail return ERROR

MMEM:COPY COPY the internal file specified by the file name to external storage.

--Syntax:

Command message: MMEM:COPY <file name>

--Data<file name>:

Data format: characters

--Example:

Set copy file name to TH9110TEST.

Command message: MMEM:COPY TH9110TEST

Return value: copy pass return OK, copy fail return ERROR

5.2.6 USB Subsystem Commands

USB:SAVE SAVE current settings to external storage file name.

--Syntax:

Command message: USB:SAVE <file name>

--Data<file name>:

Data format: characters

Return value: OK

--Example:

Set the save file name to TH9110TEST.

Command message: USB:SAVE TH9110TEST

USB:LOAD LOAD current settings to external storage file name.

--Syntax:

Command message: USB:LOAD <file name>

--Data<file name>:

Data format: characters

--Example:

Set the load file name to TH9110TEST.

Command message: USB:LOAD TH9110TEST

Return value: load pas return OK, load fail return ERROR

USB:DEL DELETE current settings to external storage file name.

--Syntax:

Command message: USB:DEL <file name>

--Data<file name>:

Data format: characters

--Example:

Set the delete file name to TH9110TEST.

Command message: USB:DEL TH9110TEST

Return value: delete pass return OK, delete fail return ERROR

USB:COPY COPY current settings to external storage file name

--Syntax:

Command message: USB:COPY <file name>

--Data<file name>:

Data format: characters

--Example:

Set the delete file name to TH9110TEST.

Command message: USB:COPY TH9110TEST

Return value: copy pass return OK, copy fail return ERROR

5.2.7 FETCH Subsystem Commands

The FETCH subsystem command is used to obtain the measurement results of the tester and is issued after the test is started until the end of the test or interrupted by other commands.

FETCH To get the measurement result.

--Syntax:

Command message:

FEtCh: AUTO <ON/OFF> or <1/0>

Query message:

FEtCh:AUTO?

--Data<ON/OFF> or <1/0>

Data format: character

Data range: 0 (OFF), 1 (ON)

--Example:

Set auto returned test result to ON.

Command message: FEtCh:AUTO ON

Query message: FEtCh:AUTO?

Return value: ON

FEtCh? Output the test result.

Command Syntax: FEtCh? After the tester receives this command, the tester will automatically issue the test results for all steps until the end of the test.

Return Format: test steps: test mode, actual test voltage (kV) ,actual test current (A), test result;

Example: STEP 1:AC,1.000,1.000e-3,PASS; STEP 2:DC,1.500,0.100e-3,PASS;

Test Steps: 1, test mode: AC, actual test voltage 1kV, actual test current 1mA, test result:PASS;

Test Steps: 2, test mode: DC, actual test voltage1.5kV, actual test current 0.1mA, test result:PASS;

Note: The tester will automatically return each test result by default (per step test result).

5.2.8 Other Commands

***IDN** Inquiry about the model and version information of the instrument.

Return message: <manufacturer>,<model>,<firmware><NL^END>

Where,

<manufacturer> Gets the manufacturer name (Tonghui)

<model> Gets the machine model (such as TH9110/9110A)

<firmware> Gets the version number of firmware (such as Version1.0.5)

For example: *IDN?

FUNC:START

Start Test

***STOP**

Stop Test

Chapter 6 Specification

Model		TH9120A	TH9120D	
Test mode		AC/OSC	DC/IR	
Withstand voltage test				
Output voltage	AC	Voltage range	0.05-10.0kV	-----
		Voltage waveform	50/60Hz $\pm 0.1\%$ Sine wave	-----
		Output power	200VA(10.0kV 20mA)	-----
	DC	Voltage range	-----	0.05-12.0kV
		Output power	-----	120VA(12.0kV 10mA)
		Load change rate	$\pm(1\% \text{ set value} + 10V)$ (rated power)	
Voltage resolution		2V		
Voltage accuracy		$\pm(1\% \text{ set value} + 0.1\% \text{ full scale})$		
Current test range	AC	Current range	0.001mA-20mA	-----
		Current resolution	0.001mA	-----
		Current accuracy	0.100mA-2.999mA	-----
			$\pm(1\% \text{ reading} + 0.5\% \text{ full scale})$	-----
			3.00mA-20.00 mA	-----
		DC	Current range	-----
	Current resolution		-----	0.1 μ A
	Current accuracy		-----	$\pm(1\% \text{ reading} + 0.5\% \text{ full scale})$
	Maximum short circuit current		40mA (AC test only)	-----
Fast discharge function		-----	Automatic discharge after test (DCW)	
Insulation resistance test				
Output voltage		-----	DC:0.05-5.0kV	
Voltage resolution		-----	2V	
Voltage accuracy		-----	$\pm(1\% \text{ set value} + 0.5\% \text{ full scale})$	
Resistance test range		-----	0.1M Ω - 50.0G Ω	

Resistance test accuracy	Voltage \geq 0.5kV	-----	1M Ω –1G Ω \pm (3% reading + 0.1% full scale)
			1G Ω –10G Ω \pm (7% reading + 2% full scale)
	Voltage<500V	-----	10G Ω –50G Ω \pm (10% reading + 1% full scale)
			0.1M Ω –1G Ω \pm (5% reading + 2% full scale)
Arc detection			
Program setting	AC	1.0mA–20.0mA	-----
	DC	-----	1.0mA–10.0mA
OSC open and short detection			
Sampling standard capacitance range	0.001—40nF	-----	
Open circuit judgment range	10%—100%	-----	
Short circuit judgment range	100%—500%	-----	
Time setting			
Test time	0.3—999s, 0 means continuous test		
Rise time	0.1—999s, 0 means OFF		
Fall time	0.1—999s, 0 means OFF		
Waiting time	0.1—999s, 0 means OFF (DC withstand voltage only)		
Safety protection function			
Shock protection	0.5mA \pm 0.25mA. Optional: ON or OFF		
Start protection (Interlock)	When the pin is connected with low terminal, high voltage output is allowed.		
Panel operation protection	Key lock, password		
Alarm indication	PASS: short sound, green light; FAIL: long sound, red light		
Storage and interface			
Internal memory	100 files can be stored and 50 steps can be edited in each file		
Standard interface	RS232、USB DEVICE、USB HOST、LAN、HANDLER		
Optional interface	GPIB		
Ambient temperature and humidity			
Parameter comparison temperature	18 $^{\circ}$ C~28 $^{\circ}$ C, Humidity: 30%~70%RH		
Normal working temperature	0 $^{\circ}$ C~45 $^{\circ}$ C, Humidity: 20%~90%RH		

Chapter 7 Warranty

Warranty period: the warranty period is one year calculated from the date of shipment from our company. The warranty card should be issued for the warranty service. During the warranty period, if the buyer damages the tester due to improper operation, the maintenance cost shall be borne by the buyer. Our company is responsible for lifelong maintenance of the tester.

The maintenance of the tester requires professional and technical personnel to carry out; please do not replace the internal components of the tester without authorization; after the tester is repaired, it needs to be re-calibrated to avoid affecting the test accuracy. Due to the blind maintenance of the user, the tester damage caused by replacing the tester's parts is not covered by the warranty, and the user should bear the maintenance cost.

The tester should be protected from sun and moisture and should be used correctly in the environment described in 1.2.

If the tester is not used for a long time, it should be packed and sealed in the original package provided by the factory.

